



Collimare®

Collimator Operator & Installation Instruction Manual

For Models:

**CPL
CML**

**Part Number: CP-15-0002
Rev: 1D**

Original draft written in English.

**Collimare, LLC
13401 W 43rd Drive
Unit # 7
Golden, CO 80403
P: 303.278.1496
F: 303.278.1498**



Revision Record:

Revision: A 001	Initial Release	Date: 04.16.2014
Revision: A 002	Revised Voltage and Current Date	Date: 04.16.2014
Revision: A 003	Revised Laser Standards	Date: 05.14.2014
Revision: A 004	Revised Environmental Range & Information Statement	Date: 08.20.2015
Revision: A 005	Included AR, Notified Body and ETL Mark Information	Date: 08.20.2015
Revision: A 006	Included Extra Mounting Instruction Information	Date: 09.04.2018
Revision: A 007	Included External Laser Adjustment Information	Date: 08.01.2019
Revision: A 008	Replaced Electrical Connections Figure with Wiring Diagram and Schedule	Date: 02.20.2020
Revision: A 009	Revised Part List	Date: 02.24.2020
Revision: 1B	Manual Overhaul - Revised Layout, Grammar, and Contents	Date: 10.29.2021
Revision: 1C	Added Tube Mount Installation Pictures and improved some drawings	Date: 06.15.2023
Revision: 1D	Added Schematics for LED Board Version B and updated Schematics for Version A	Date: 03.25.2024

Model Specifications as identified by the Catalog # on the Serial Tag:

Catalog #:	Usage Type	Voltage & Current	Frequency	Skin Guard	Certified Human Use	Lamp Type
CPL-All Models	Portable	12-24VDC / 24V AC @ 1A-2A	DC/50/60Hz	Yes & No	Yes & No	LED
CML-All Models	Clinical	12-24VDC / 24V AC @ 1A-2A	DC/50/60Hz	No	Yes & No	LED

Essential Performance and Risk Analysis:

Guidance and Manufacturer’s Declaration of Electromagnetic Emissions:

Compliance Verification:

Compliance Verification Record Sheet:

Appendix 1

Appendix 2

Appendix 3

Appendix 4

References:

- Sub-Chapter J of Title 21 of the Code of Federal Regulations, “Diagnostic X-Ray Systems and their Major Components” (Referenced as CFR Sub-Chapter J.)
- The National Council on Radiation Protection (NCRP) No. 33, “Medical X-Ray and Gamma-Ray Protection for Energies up to 10 MeV-Equipment Design and Use”

Conforms to ANSI/AAMI STD ES60601-1

Certified to CSA STD C22.2 No. 60601-1

ETL CLASSIFIED



Intertek
3137240

TABLE OF CONTENTS

TABLE OF CONTENTS	3
LIST OF FIGURES	5
1.0 INSTALLATION INSTRUCTION ADVISORY	6
2.0 INTRODUCTION	8
2.1 YOU HAVE LEGAL OBLIGATIONS	8
2.2 BACKGROUND / INTENDED USAGE	8
2.3 RADIATION AND MECHANICAL/ELECTRICAL WARNING	9
2.4 COMPATIBILITY	10
2.4.1 Focal Distance of X-Ray Tube	10
2.4.2 Leakage Radiation	10
2.4.3 Inherent Filtration and Half-Value Layer	10
2.4.4 Application	10
2.4.5 Installation	10
2.4.6 Collimator Electrical Requirements	10
2.5 MAINTENANCE	11
2.5.1 Preventive Maintenance	11
2.5.2 Service Maintenance	11
2.5.3 Cleaning & Disinfecting	11
2.5.4 Mechanical Components	11
2.6 COMPLIANCE REQUIREMENTS	11
3.0 <i>COLLIMATOR MODEL INFORMATION</i>	12
3.1 CONTROL PANEL	12
3.2 MODEL DIMENSIONS	13
3.3 LED BOARD VERSIONS	14
3.3.1 LED Board Version A (Collimators with Serial Numbers before A14387)	14
3.3.2 LED Board Version B (Collimators with Serial Numbers greater than A14386)	14
3.4 OPERATION AND FEATURES	15
3.4.1 Unit Power	15
3.4.2 Light and Laser Operation	15
3.4.3 Light and Laser On Time	15
3.4.4 LED Brightness (LED Board Version B Only)	15
3.4.5 Thermal Safety Limit	15
3.4.6 LED Replacement	15
4.0 INSTALLATION INSTRUCTIONS	16
4.1 COLLIMATOR MOUNTING	16
4.1.1 Focal Distance of X-Ray Tube	16
4.1.2 Lead Aperture, Diaphragm, or Input Cone	16
4.1.3 Aluminum Filter Installation	16
4.1.4 Mounting Instructions: Collimator to X-Ray Tube	18
4.1.5 Mounting Instructions: Collimator to Portable X-Ray Unit	23
4.2 ALIGNMENT OF X-RAY FIELD TO LIGHT FIELD	25
4.3 LIGHT AND LASER ADJUSTMENT	26
4.3.1 Light Field Adjustment	26
4.3.2 Internal Laser Adjustment (Collimators with Serial Numbers before A08323)	28
4.3.3 External Laser Adjustment (Collimators with Serial Numbers after A08322)	28
4.4 ELECTRICAL CONNECTIONS	31

4.4.1 Confirming Isolated AC Power	31
4.4.2 LED Replacement	31
4.4.3 LED Board Assembly Replacement	31
4.4.4 External 25' Power Interface Cable	31
4.4.5 Collimator 25' Interface Cable Wiring Diagram – Version A	34
4.4.6 Collimator 25' Interface Cable Wiring Diagram – Version B	35
5.0 SERVICE INSTRUCTIONS	36
5.1 - KNOB REMOVAL	37
5.2 - HOUSING REMOVAL	38
5.3 - BEZEL / SKIN GUARD REMOVAL	39
5.4 - LED BOARD REPLACEMENT	40
6.0 REPLACEMENT PART LISTING	41
APPENDIX 1: ESSENTIAL PERFORMANCE AND RISK ANALYSIS	46
APPENDIX 2: ELECTROMAGNETIC EMISSIONS	47
APPENDIX 3: COMPLIANCE VERIFICATION	51
A3.1 - LIST OF FIGURES AND TABLES	51
A3.2 - VERIFICATION TESTS TO BE PERFORMED	51
A3.3 - XR8/2.09 BEAM QUALITY (HALF-VALUE LAYER (HVL))	57
A3.3.1 - METHOD 1 - VISUAL DETERMINATION OF HALF-VALUE LAYER (HVL)	57
A3.3.2 - METHOD 2 - STANDARD ABSORBER METHOD	58
A3.4 - XR8/2.13 ACTUAL VERSUS INDICATED SOURCE-TO-IMAGE DISTANCE (SID)	59
A3.4.1 - METHOD 1 - DIRECT MEASUREMENT METHOD	59
A3.4.2 - METHOD 2 - TRIANGULATION METHOD	59
A3.5 - XR8/2.14 VISUAL DEFINITION (RADIOGRAPHIC) OR X-RAY LIGHT-FIELD	60
A3.5.1 - METHOD 1 - BRH/FDA COMPLIANCE TEST METHOD	60
A3.5.2 - METHOD 2 - METAL MARKER METHOD	61
A3.5.3 - METHOD 3 - ALTERNATE TEST STAND METHOD	62
A3.6 - XR8/2.15 INTENSITY OF LIGHT-FIELD ILLUMINATION	63
A3.6.1 - METHOD 1 - DIRECT TEST	63
A3.6.2 - METHOD 2- INDIRECT TEST	63
A3.7 - XR8/2.17 X-RAY FIELD/RECEPTOR CENTER ALIGNMENT	64
A3.8 - XR8/2.18 INDICATION OF X-RAY FIELD SIZE	65
A3.9 - XR8/2.20 X-RAY FIELD LIMITATION AND ALIGNMENT	66
A3.9.1 - METHOD 1 - FDA/CDRH TEST STAND METHOD	66
A3.9.2 - METHOD 2 - ALTERNATE TEST STAND METHOD	67
A3.9.3 - METHOD 3 - CASSETTE METHOD	67
APPENDIX 4: COMPLIANCE VERIFICATION RECORD SHEET	68

LIST OF FIGURES

FIGURE 1 - CONTROL PANEL	12
FIGURE 2 - DIMENSIONS - CML AND CPL COLLIMATOR MODEL	13
FIGURE 3 - FILTRATION INSTALLATION	17
FIGURE 4 - COLLIMATOR TUBE MOUNT ASSEMBLY INSTALLATION	20
FIGURE 5 - PROPERLY SEATED MOUNTING LUG SLIDE ON THE FLANGE OF MOUNTING RING	21
FIGURE 6 - CML X-RAY TUBE MOUNTING ASSEMBLY	22
FIGURE 7 - PORTABLE HEAD MOUNTING ASSEMBLY	24
FIGURE 8 - LIGHT FIELD ADJUSTMENT	27
FIGURE 9 - INTERNAL LASER ADJUSTMENT	29
FIGURE 10 - EXTERNAL LASER ADJUSTMENT	30
FIGURE 11 - LED BOARD VERSION A WIRING DIAGRAMS	32
FIGURE 12 - LED BOARD VERSION B WIRING DIAGRAMS	33
FIGURE 13 - KNOB REMOVAL	37
FIGURE 14 - HOUSING REMOVAL	38
FIGURE 15 - SKIN GUARD REMOVAL	39
FIGURE 16 - LED BOARD REPLACEMENT	40
FIGURE A3.1 – GENERAL SET-UP BRH/FDA TEST STAND	52
FIGURE A3.2 – BRH/FDA TEST STAND SHOWING CHAMBER MOUNTING SLOTS	53
FIGURE A3.3 – LIGHT FIELD VS. X-RAY FIELD ERROR MEASUREMENTS	54
FIGURE A3.4 – DETERMINATION OF SID	55
FIGURE A3.5 – METAL MARKER METHOD	56
TABLE A3.1 - MINIMUM BEAM QUALITY REQUIREMENTS	57
TABLE A3.2 - ALUMINUM EQUIVALENT OF PRIMARY BEAM TOTAL FILTRATION	57

1.0 INSTALLATION INSTRUCTION ADVISORY

INSTALLATION INSTRUCTION ADVISORY

TO: INSTALLERS, SERVICE PERSONNEL, AND TECHNICIANS

It is required to read and carefully review the instructions and cautions contained within this manual even if you are very familiar with the installation and operation of similar equipment. It is necessary for the assembler/installer to verify compliance. A series of tests, when performed at the time of installation, will indicate compliance with 21 CFR, Sub-Chapter J, Part 1030, Performance Standards. These tests are described in Appendix 3, "Compliance Verification," and must be performed before releasing the collimator for use. A record sheet is provided in Appendix 4 and should be completed by the installer. In order to facilitate a timely installation and ensure compliance it is recommended that the installer review this manual in its entirety and then, starting at the beginning, follow all procedures in each section in order.

Upon request Collimare will make available all circuit diagrams, component parts lists, and all other information available to assist Service Personnel in the service and repair of the unit.



The useful x-rays and scattered radiation are dangerous to the operator and others in the vicinity unless safe exposure procedures are strictly observed. Failure to follow the procedures and requirements in this manual may result in excess radiation exposure, an electrical and/or mechanical safety hazard, failure to meet governmental requirements, as well as damage to the collimator.



This unit utilizes two low power (<700 μ watt 650 nm, IEC 60825-1:2007) Class 1 lasers to produce an alignment crosshair. **Per OSHA Laser Classification—Summary of Hazards Table, Class 1 lasers pose no hazard to direct ocular, or diffuse ocular exposure.**

Complies with 21 CFR 1040.10 and 1040.11 except for deviations pursuant to Laser Notice No. 50 dated July 26, 2001

Environmental Range

Altitude: (All Modes), 0 to 10,000 feet (0 to 3048 meters)

Air Pressure: (All Modes), 70 to 106 kPa

Ambient temperature (Operating): +50°F (+10°C) to +80°F (+27°C)

Ambient temperature (Shipping, Storage): -4°F (-20°C) to +122°F (+50°C)

Relative Humidity (Operating): 5 to 85% Non-condensing

Relative Humidity (Shipping, Storage): 5 to 95% Non-condensing



LED USAGE shall not exceed 2 minutes of accumulative on time (4 thirty “30” second or 2 sixty “60” second cycles) without a cool down period of 2 minutes.



The LED heat sink and LED may be hot enough to cause severe burns. Do not touch any objects in the LED area with bare skin.



The intensity of the LED light output is sufficient to temporarily impair your vision if allowed to enter the eyes directly. Make sure that the power is off when removing the LED heat sink. Do not turn the power on with the LED heat sink removed. Take precautions to prevent direct or accidental light from the LED to directly enter the eyes.



Disconnect primary power to the Collimator anytime the covers are off.



End of Life Disposal: This Collimator contains lead, a hazardous material, and other recyclable materials and should be properly disposed of according to local regulations and by specialized companies.

2.0 INTRODUCTION

This manual contains information for the assembly, installation, adjustment, testing and maintenance of the collimators manufactured by Collimare, LLC.

2.1 YOU HAVE LEGAL OBLIGATIONS

The manufacturers of beam limiting devices are required to provide instructions for the assembly, installation, adjustment and testing adequate to assure compliance with applicable provisions of DHHS Performance Standards 21 CFR Sub-Chapter J. Part 1020.

Those who assemble or service beam limiting devices must follow the instructions of the original manufacturer and process the FDA-2579 Assemblers Report where applicable.

You assume responsibility for compliance of this product if you fail to follow the original manufacturer's instructions or modify any component which affects radiation safety.

The FDA (CDRH) requires that manufacturers must include a specific requirement that the assembler perform all applicable tests at the time of installation. A thorough explanation of the equipment required and step-by step instructions must be provided by the manufacturer (Appendix 3). The instructions include a requirement to record key data to demonstrate at a later time that all tests were performed and that the equipment was left in full compliance with the standards.

As an assembler, you must perform these tests for the applicable requirements at the time of installation and following any repairs which could alter the performance.

A Compliance Data Log is provided in this manual (Appendix 4) to record the results of the tests.

2.2 BACKGROUND / INTENDED USAGE

The operation of an X-Ray collimator is restricted to a trained and licensed x-ray technician/personnel or physician.

An X-ray collimator functions as an apparatus for regulating the cross-sectional size and shape of a beam of radiation which emerges from an X-ray tube.

The source of radiation is virtually a point-source and, due to the tube housing design, emerges from the port as a solid diverging cone of radiation. The finite angle of the anode surface limits the X-ray beam on the anode side (heel-effect) forming a "D" shaped X-ray field, limiting the useful coverage.

In "collimating" a beam to a given size and shape, a flat-pair of lead shutters are moved perpendicularly into the beam to absorb the unwanted portion of the emerging beam. A second flat-pair of shutters are positioned at right angles to the first pair, and again are moved perpendicularly into the beam. In this manner a continuously variable square/rectangular beam is formed.

The landing area of the beam will contain a radiographic or fluoroscopic image receptor located in a plane perpendicular to the beam at predetermined distances from the radiation source (focal spot).

The size and shape of the image receptor will determine the maximum useful cross-sectional size and shape of the beam in the plane of the image receptor. The source to image receptor distance (SID) determines the actual shutter opening required to regulate the beam size and shape in the plane of the image receptor.

The primary objective of the collimator is to limit the beam to the size of the image receptor and to provide other standardized operations consistent with the DHHS Performance Standards 21 CFR Sub-Chapter J. This is accomplished by measuring the size of the image receptor and the distance (SID) involved, then adjusting the collimator accordingly or by visual means of the light field with respect to the area of interest or image receptor size whichever is smaller.

2.3 RADIATION AND MECHANICAL/ELECTRICAL WARNING

(from NEMA Standards Publication/No. XR8-1979)



Radiation Warning for Diagnostic X-Ray Systems

X-rays are dangerous to both operators and others in the vicinity unless established safe exposure procedures are strictly observed.

The useful and scattered beams can produce serious, genetic or potentially fatal bodily injuries to any persons in the surrounding area if used by an unskilled operator. Adequate precautions must always be taken to avoid exposure to the useful beam, as well as to leakage radiation from within the source housing or to scattered radiation resulting from the passage of radiation through matter.

Those authorized and licensed to operate, test, participate in or supervise the operation of the equipment must be thoroughly familiar and comply completely with the currently established safe exposure factors and procedures described in publications such as Sub-Chapter J of Title 21 of the Code of Federal Regulations, "Diagnostic X-Ray Systems and their Major Components", and the National Council on Radiation Protection (NCRP) No. 33, "Medical X-Ray and Gamma-Ray Protection for Energies up to 10 MeV-Equipment Design and Use", as revised or replaced in the future.

Failure to observe these warnings may cause serious, genetic or potentially fatal bodily injuries to the operator or those in the area.



Mechanical/Electrical Warning for Diagnostic X-Ray Systems

All of the moveable assemblies and parts of X-ray equipment should be operated with care. Only properly trained and qualified personnel should be permitted access to any internal parts. Live electrical terminals can cause bodily injury or death; be sure line disconnect switches are opened and other appropriate precautions are taken before opening access doors, removing enclosure panels, or attaching accessories.

When servicing x-ray equipment always follow the manufacturer's procedures.

Do not remove the flexible high tension cables from the X-ray tube housing or high tension generator or the access covers from the generator until the main and auxiliary power supplies have been disconnected.

When disconnecting high voltage cables, they must be grounded immediately in order to dissipate any electrical charge that may remain on the cables or the tube.

Failure to comply with the foregoing may result in serious or potentially fatal bodily injuries to the operator or those in the area.

2.4 COMPATIBILITY

The collimators are compatible and can be adapted for use with X-ray tube/housing assemblies that meet all of the following factors:

2.4.1 Focal Distance of X-Ray Tube

The focal spot to x-ray tube mounting ring top surface distance must be:

CPL MODEL: Between 1.52 - 2.05 inches depending on the model**

CML MODEL: 2.44 inches, tolerance of +/- 0.031 inches (1/32")

**Refer to the portable x-ray manufacturer's literature for your specific model focal distance.

Do not rely on tube markings, only reference the x-ray tube data sheet or literature.

Note: Include any X-ray tube mounting plates or spacers when calculating the Focal Spot to Collimator Mounting distance per the equipment and X-ray tube manufacturer's published data.

2.4.2 Leakage Radiation

Maximum leakage radiation from the X-ray tube/housing assembly must not exceed 100 mR/hr at 40 inches (1 meter) at 125 kVp at 4ma or 150 kVp depending on model (see the serial tag for kVp rating).

2.4.3 Inherent Filtration and Half-Value Layer

The collimator has a minimum value of 1.4 mm aluminum equivalence at 80 kVp. This value plus any tube inherent filtration plus any added filtration must meet the minimum requirements of 21 CFR Sub-Chapter J, part 1020.30 (m) (1) Table 1 on beam quality and/or your local and state requirements (e.g. minimum HVL at 100 kVp must be 3.6mm AL)

2.4.4 Application

The intended application is for portable, over-table general purpose radiographic fluoroscopic equipment including tomographic and chest applications. Maximum tube rating must not exceed 150 kVp or 125 kVp per the rating on the serial tag of the collimator.

2.4.5 Installation

Must be installed with the supplied hardware including mounting flange, spacers (as required), and bolts equally spaced on a 3.62" diameter bolt center. Portables must be mounted per the manufacturer's requirements. Refer to manufacturer's documentation for mounting specifications.

2.4.6 Collimator Electrical Requirements

This is a CLASS I electrical device and must be wired in accordance with all applicable electrical codes and regulations. The power supply cable from the power supply to the Collimator must be sized to handle the full continuous rated load taking into consideration the distance from the collimator to the power supply.

Power Supply Requirement(s) (to comply with light output requirement):

LED Board Version A: 12VDC-24VDC & 24V Isolated AC 50/60Hz @ 1A - 2A. Not Polarized

LED Board Version B: 12VDC-24VDC & 24V AC 50/60Hz @ 1A-2A. Polarized

LED Board Version A requires an isolated, primary and secondary fused AC transformer or DC power supply.

Note: Refer to 4.4.1 Confirming Isolated AC Power, page 31, on how to confirm your AC Power is Isolated.

2.5 MAINTENANCE

The collimator system must be properly maintained to assure both compliance with the CDRH regulations and useful life.

2.5.1 Preventive Maintenance

Preventive maintenance is to be performed once every twelve months. This includes inspection of the collimator tube mount, electrical cables, electrical connections, cleaning and lubrication of the collimator.

2.5.2 Service Maintenance

Service Maintenance should also occur if any of the following conditions occur:

- Lamp or LED replacement.
- Premature electronic component failure.
- When the collimator is removed from the tube or housing assembly.
- When the collimator has been subjected to external damage.
- If the operator had determined there is a problem.

2.5.3 Cleaning & Disinfecting

Turn off power to the collimator before cleaning.

Never use a solvent based, abrasive, spray/aerosol, wax, acid or alkaline type cleaners.

Never directly use any type of spray or foaming cleaner.

Housing: Use only a soft cloth lightly moistened with a mild detergent soap.

Crosshair window: Use only a soft cloth lightly moistened with a mild detergent soap or plastic cleaner.

Field light mirror: Use only a soft cloth, lightly moistened with isopropyl alcohol and allow to air dry.

Disinfect control surfaces before each use with a 70% isopropyl alcohol dampened soft cloth.

2.5.4 Mechanical Components

Tube mount should be disassembled, cleaned and reassembled using a **Synthetic Brake Grease** at the contact surfaces of the plastic tube mount, aluminum mounting ring and the bottom pads of the tube mount. The top surface of the collimator that contacts the tube mount should also be cleaned.

Internal shutters and shafts should be wiped clean with a soft cloth, lightly moistened with isopropyl alcohol, while moving the shutters back and forth. **DO NOT GREASE. THE SHUTTERS ARE DESIGNED TO RUN DRY.** If any lubricant is needed a light silicon spray can be applied and then wiped off.

Synthetic Brake Grease such as CRC is available at most auto stores and Walmart.

**** DO NOT USE A LITHIUM BASED GREASE. ****

2.6 COMPLIANCE REQUIREMENTS

It is necessary for the assembler to verify compliance. A series of tests, when performed at the time of installation, will indicate compliance with 21 CFR, Sub-Chapter J, Part 1030, Performance Standards. These tests which are described in Appendix 3, "Compliance Verification," and must be performed before releasing the collimator for use. See Appendix 4 for a record sheet that is to be completed by the installer.

3.0 COLLIMATOR MODEL INFORMATION

The collimator model number indicates the application the collimator can be used for. CPL models are for portable use only with a maximum certification of 125 kVp. CML models are for use within a shielded X-Ray room with a maximum certification of 150 kVp or 125 kVp per the rating on the serial tag of the collimator.

3.1 CONTROL PANEL

COLLIMATOR CONTROL PANEL

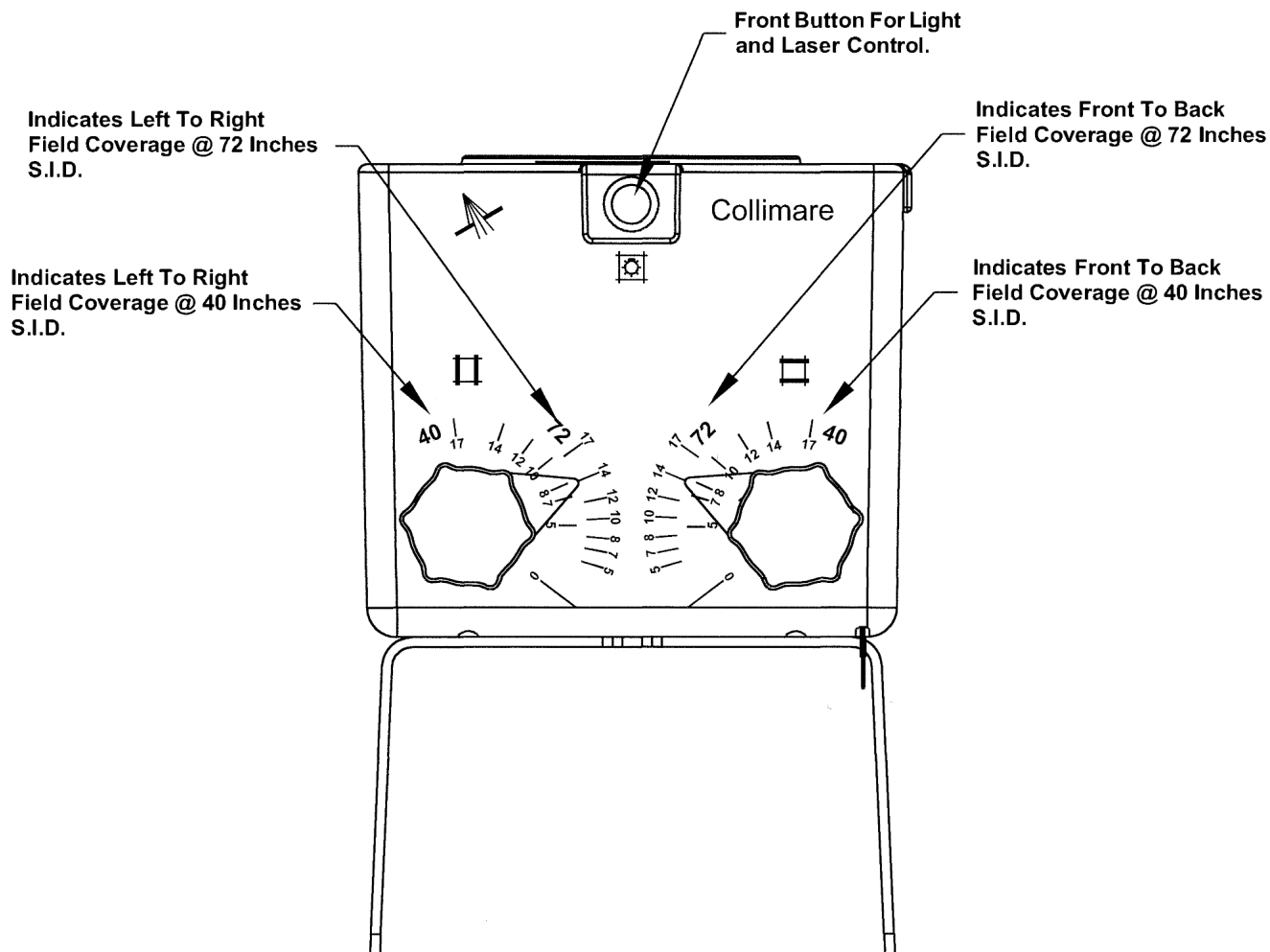

3.2 MODEL DIMENSIONS

DIMENSIONS - CML AND CPL COLLIMATOR MODEL

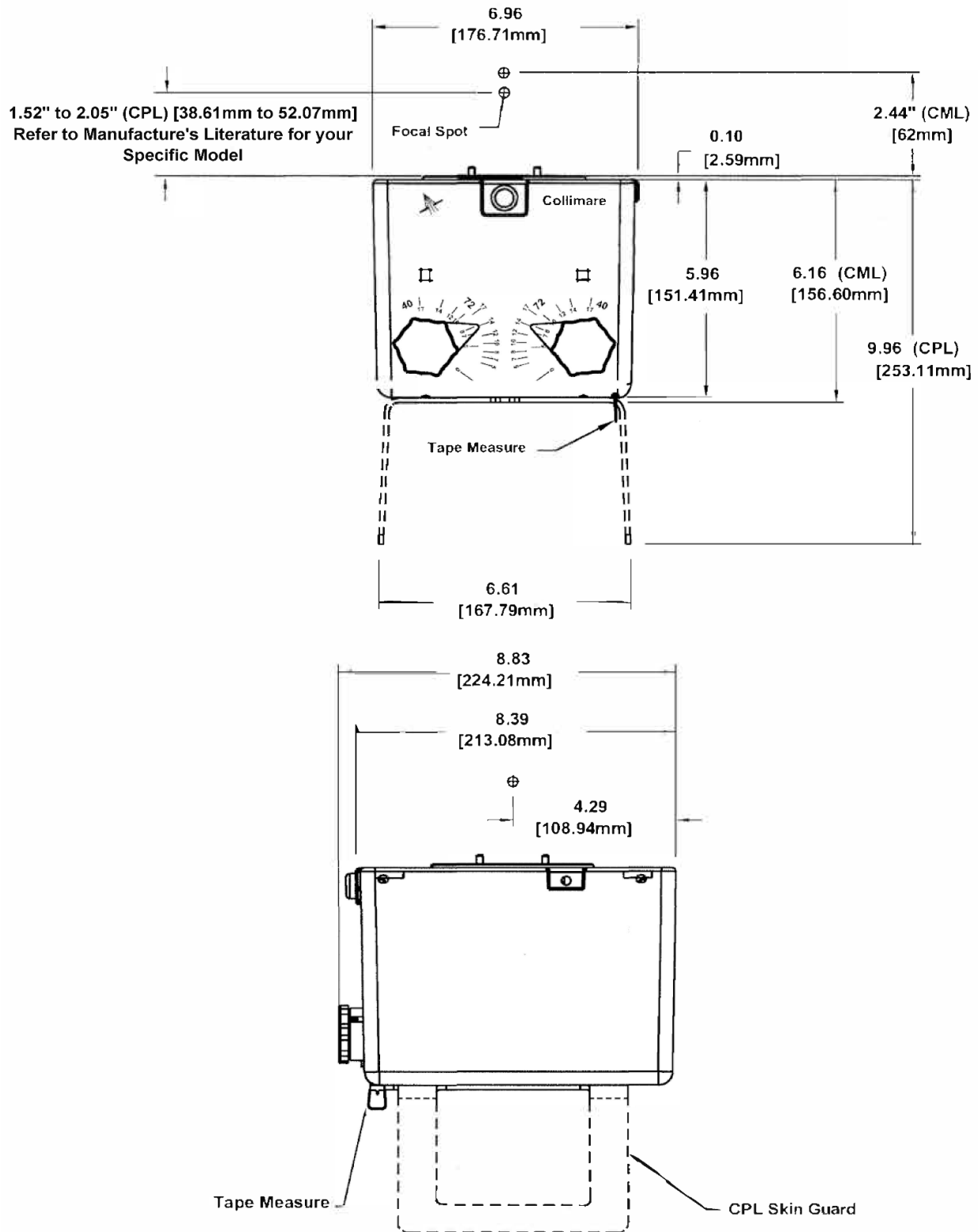

Figure 2 - Dimensions - CML and CPL Collimator Model

3.3 LED BOARD VERSIONS

3.3.1 LED Board Version A (Collimators with Serial Numbers before A14387)

Requires 12-24VDC or 24V **Isolated** AC. Power is not polarized.

Version A1

The unit has a three-wire power cord with either a 3-pin connector on the end or no connector.

Version A2

The unit has a power pigtail with a 9-pin connector on the end and external switch wiring.

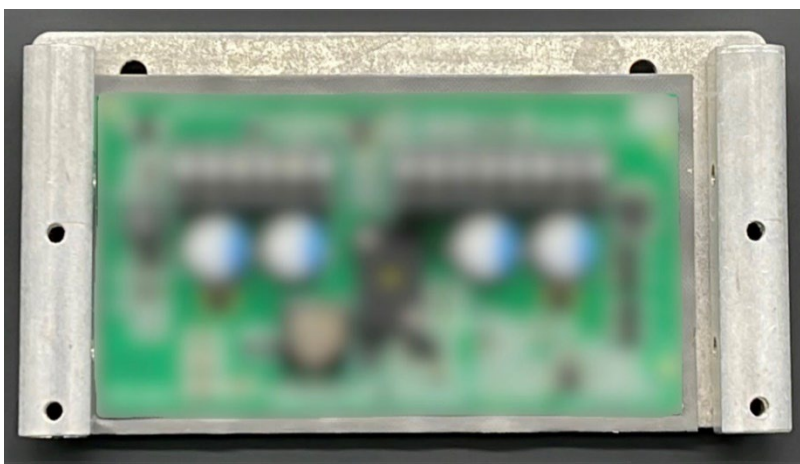

3.3.2 LED Board Version B (Collimators with Serial Numbers greater than A14386)

Requires 12-24VDC or 24V AC. (AC does not need to be isolated)

Power wires are **polarized**. Brown/Black is positive voltage, Blue/White is 0V return.

Note: Reversing the polarity will not damage the LED Board, but the board will not work until corrected.

Version B1

The unit has a three-wire power cord with either a 3-pin connector on the end or no connector.

Version B2

The unit has a power pigtail with a 9-pin connector on the end and external switch wiring.

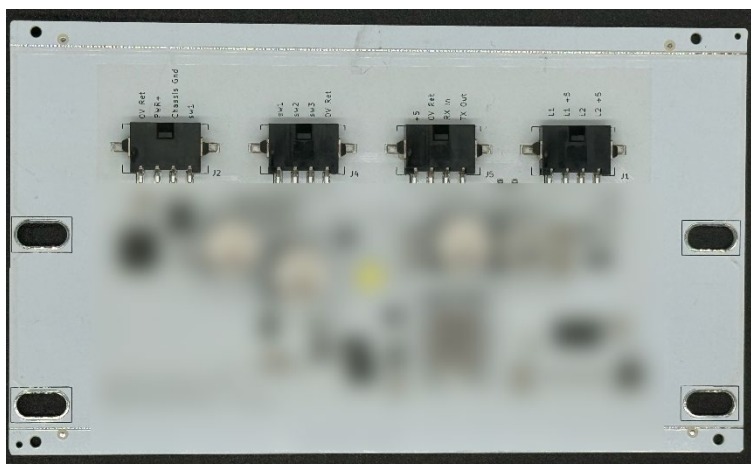

3.4 OPERATION AND FEATURES

3.4.1 Unit Power

The unit is powered by the x-ray system or external power supply. There is no independent power switch.

3.4.2 Light and Laser Operation

Light and Lasers ON

Press and release the Front Button one (1) time for Light and Lasers to come ON.

Light and/or Lasers OFF

If the Light or Lasers are ON press and release the Front Button to turn the Light and Lasers OFF.

Light ON and Lasers OFF

Press and Hold the Front Button for one (1) second then release Front Button for Light Only to come ON.

Light OFF and Lasers ON

Press and hold the Front Button until the Lasers come ON then release Front Button for Lasers Only to come ON.

3.4.3 Light and Laser On Time

The light and lasers can be programmed to stay on for up to a total of 2 minutes in 15 second intervals.

1. Unplug the collimator to remove power to the unit. Press the Front Switch to clear the capacitors.
2. With the collimator unplugged press and hold the Front Switch then apply power to the collimator.
3. After 2 seconds the Lasers will start to flash once every second. Each flash is 15 seconds ON time.
4. Once the desired ON time is reached release the Front Button.
5. The lasers will flash twice to indicate the ON Time value is stored and it has exited out of the ON Time Programming mode.

(i.e. Hold and release after 1 flash for 15 seconds, 8 flashes for 2 minutes.)

3.4.4 LED Brightness (LED Board Version B Only)

The brightness of the LED can be adjusted from 17 foot-candles to 28 foot-candles. Factory Default is 23fc.

1. Unplug the collimator to remove power to the unit. Press the Front Switch to clear the capacitors.
2. Apply power to the collimator then press and release the Front Switch 6 times. Then, press and hold the Front Switch (7th press) until the lasers start to flash (2 seconds). Each flash is an increase of 1 foot candle starting at 17 foot candles and maxing out at 28 foot candles.
3. Once the desired brightness is reached release the Front Button.
4. The lasers will flash twice to indicate the brightness value is stored and it has exited out of the Brightness Programming mode.

3.4.5 Thermal Safety Limit

Should the LED overheat, a thermal sensor will turn the LED off. The lasers will flash every second indicating the LED has overheated. Turn the unit off and allow it to cool for 10 to 15 minutes. After the LED board has cooled off it will resume normal operation.

Caution!! If the collimator is constantly overheated there can be potential damage to the LED board. The thermal safety cutoff is designed to protect the LED from overheating but is not designed to be put under constant overheating stress. If your site requires high usage, please contact Collimare for further options on how to protect the LED board from repeated overheating.

3.4.6 LED Replacement

The LED is part of the circuit board assembly and must be replaced as a whole.

4.0 INSTALLATION INSTRUCTIONS

Carefully unpack the equipment and check for visible damage incurred during shipment. Any damage should be referred to the agency that delivered the equipment. Verify all contents against the packing list and collect published data for further reference. Take care in handling the collimator and do not set it down on the output window.

4.1 COLLIMATOR MOUNTING

Determine the correct collimator spacing requirements with respect to the tube housing port boss per the manufacturer's literature and specifications. The collimator will not perform properly if the focal spot is not correct.

4.1.1 Focal Distance of X-Ray Tube

The Collimator focal spot to upper tube mounting plate distance is:

CPL MODEL: Between 1.52 - 2.05 inches depending on the model**

CML MODEL: 2.44 inches, tolerance of +/- 0.031 inches (1/32")

**Refer to the portable x-ray manufacturer's literature for your specific model focal distance.

Do not rely on tube markings, only reference the x-ray tube data sheet or literature.

Note: Include any X-ray tube mounting plates or spacers when calculating the Focal Spot to Collimator Mounting distance per the equipment and X-ray tube manufacturer's published data

4.1.2 Lead Aperture, Diaphragm, or Input Cone

The Collimator is designed to be used with a lead aperture, diaphragm or input cone in the plastic port of the X-ray tube. Ensure that there is not any mechanical interference between the collimator and the lead aperture, diaphragm, or cone in the port of the X-ray tube. If it is found that lead diaphragms or cones require removal or modification, consult the factory.

4.1.3 Aluminum Filter Installation

Install Aluminum Filtration Disks (Provided, included in Manual Bag) as instructed. (See Figure 3, Page 16)

1. Determine the needed filtration based on Half Value requirements (See Appendix 3, Table A3.1)
2. Install one or two 0.25mm Aluminum Filters as required.
3. Add small beads of RTV along the edges to retain filters to the tube mount or another installed aluminum filter.
4. Push filters up into the Tube Mount filter hole and make sure they are seated properly and secure. Make sure the RTV contacts the tube mount or another aluminum filter.

FILTRATION INSTALLATION

Determine the Needed Filtration
Based on Half Value Requirements

(See Appendix 3, Table A3.1 found in
Collimator Manual)

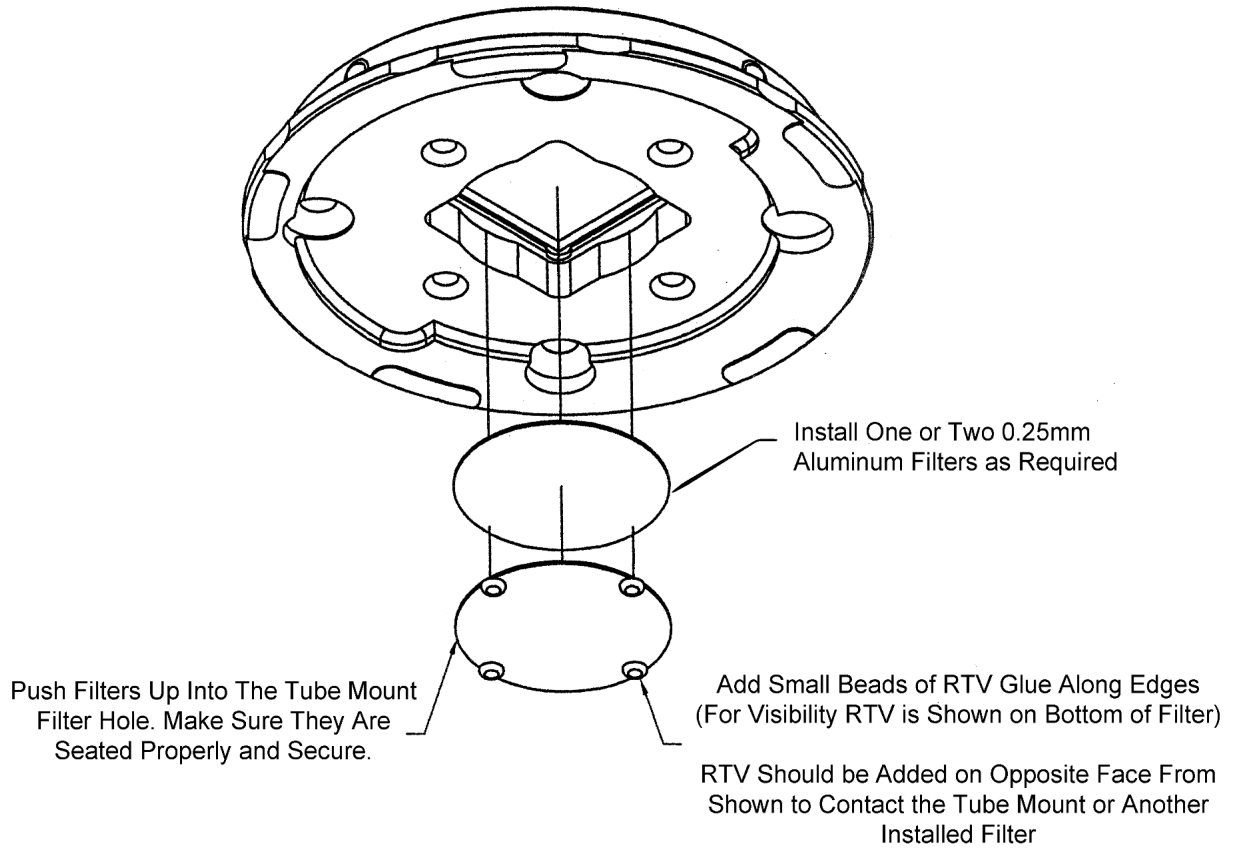
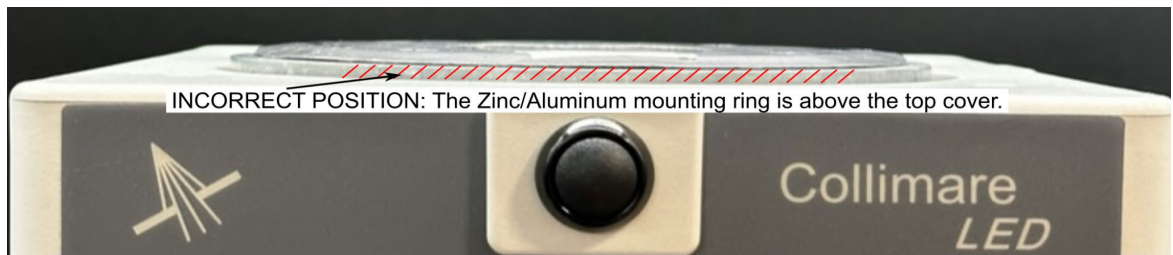

Figure 3 - Filtration Installation

4.1.4 Mounting Instructions: Collimator to X-Ray Tube

Warning!! In order to ensure a safe and secure mounting of the collimator to the X-ray tube, the following installation guidelines must be followed.

1. Determine the correct length of tube mount screws to use considering the collimator spacing requirements with respect to the tube housing port boss per the manufacturer's literature and specifications.
 - CML Model: Included with the collimator in the installation bag.
 - M6-1.0 x 30mm Flat Head Screws
 - M6-1.0 x 35mm Flat Head Screws
 - 1/4-20" x 1-1/4" Flat Head Screws
 - CPL Model: Screws are provided by the manufacturer of the portable x-ray system.
2. Remove the tube mount assembly from the top of the collimator by backing the mounting lug adjustment screws all the way out, a minimum of 3 full CCW turns. When removing the tube mount assembly take note that the zinc/aluminum mounting ring is flush with the top of the top cover.
3. Calculate the required number of tube mount shims to obtain a focal spot distance of 2.44 inches per the X-ray tube manufacturer's specifications (Figure 2, Page 13 and Figure 6, Page 21).
4. Install the tube mount assembly and shims onto the X-ray tube with the stop-pin cut out to the front (Figure 6, Page 21). A medium strength thread locking compound, such as Loctite #242 must be applied to the screws before securing the tube mount to the X-ray tube.
5. Lift the collimator up to fully seat the mounting ring. It is critical to ensure that the zinc/aluminum mounting ring is flush with the top cover as shown below. Using an 1/8" Allen wrench, tighten each of the mounting lug screws a minimum of 3 full CW turns to an even pressure. Once the screws are tight, back off each screw 1/8 turn and rotate the collimator to align the laser crosshairs with the table or bucky.



6. Once the collimator has been aligned, use a torque screwdriver to apply torque incrementally up to 20 inch-pounds (2.26 Newton meters) to the mounting lug screws. For example, apply 10 in-lbs to each of the four mounting lug screws sequentially, then apply 15 in-lbs to each, then 20 in-lbs. With proper execution of this procedure, there should be a slight drag in the rotation of the collimator on the mounting ring.
7. Align the Light field to the X-Ray field per the instructions in Section 4.2 Alignment of X-Ray Field to Light Field found on page 24.

8. After mounting the collimator and/or performing any service to it or the tube housing, inspect the fit of the collimator and tube housing assembly. Ensure the collimator can freely rotate between detent locks while inspecting for loose joints or gaps between the tube/collimator assembly or the mounting area.

Failure to adhere to the above guidelines may result in damaged tube mount screws, mount failure, or unsecured collimator mounting clamps which could result in heavy components falling during use. Incidents of loose system components should be reported immediately to X-ray service personnel for repair.

COLLIMATOR TUBE MOUNT ASSEMBLY INSTALLATION

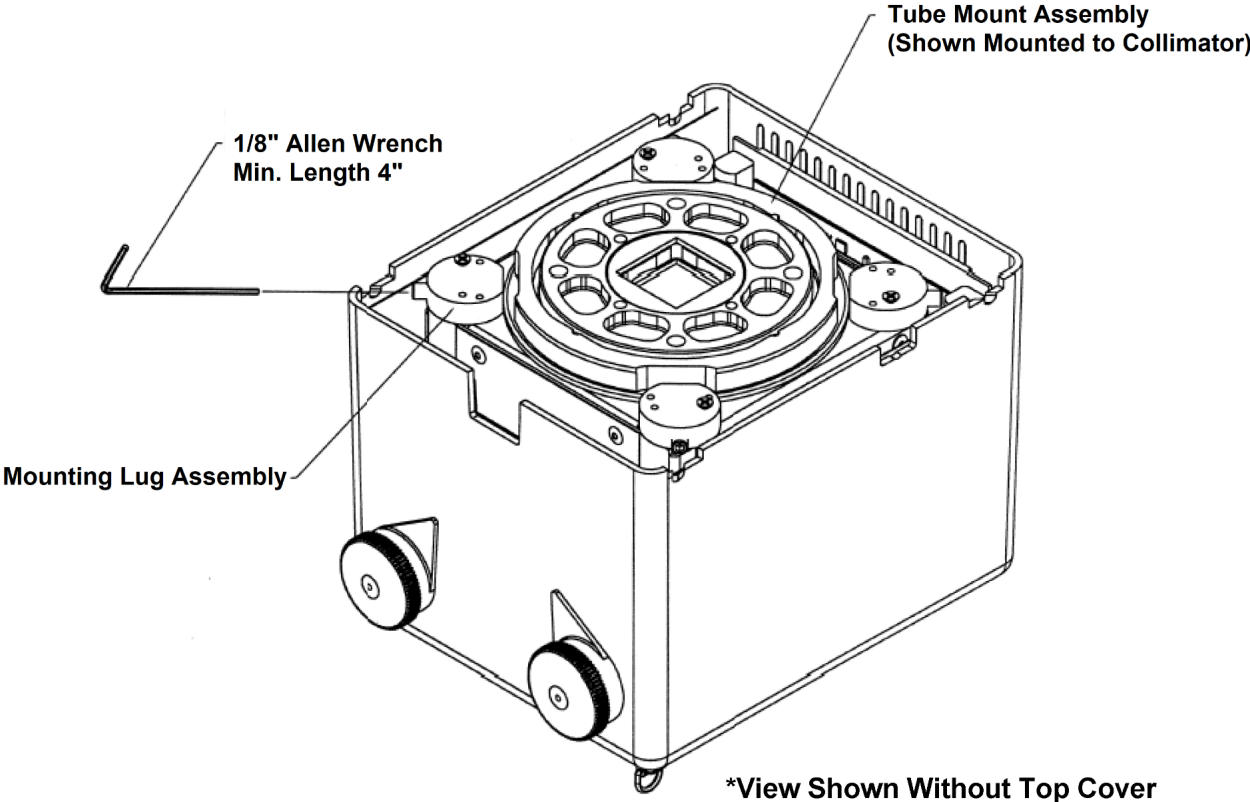
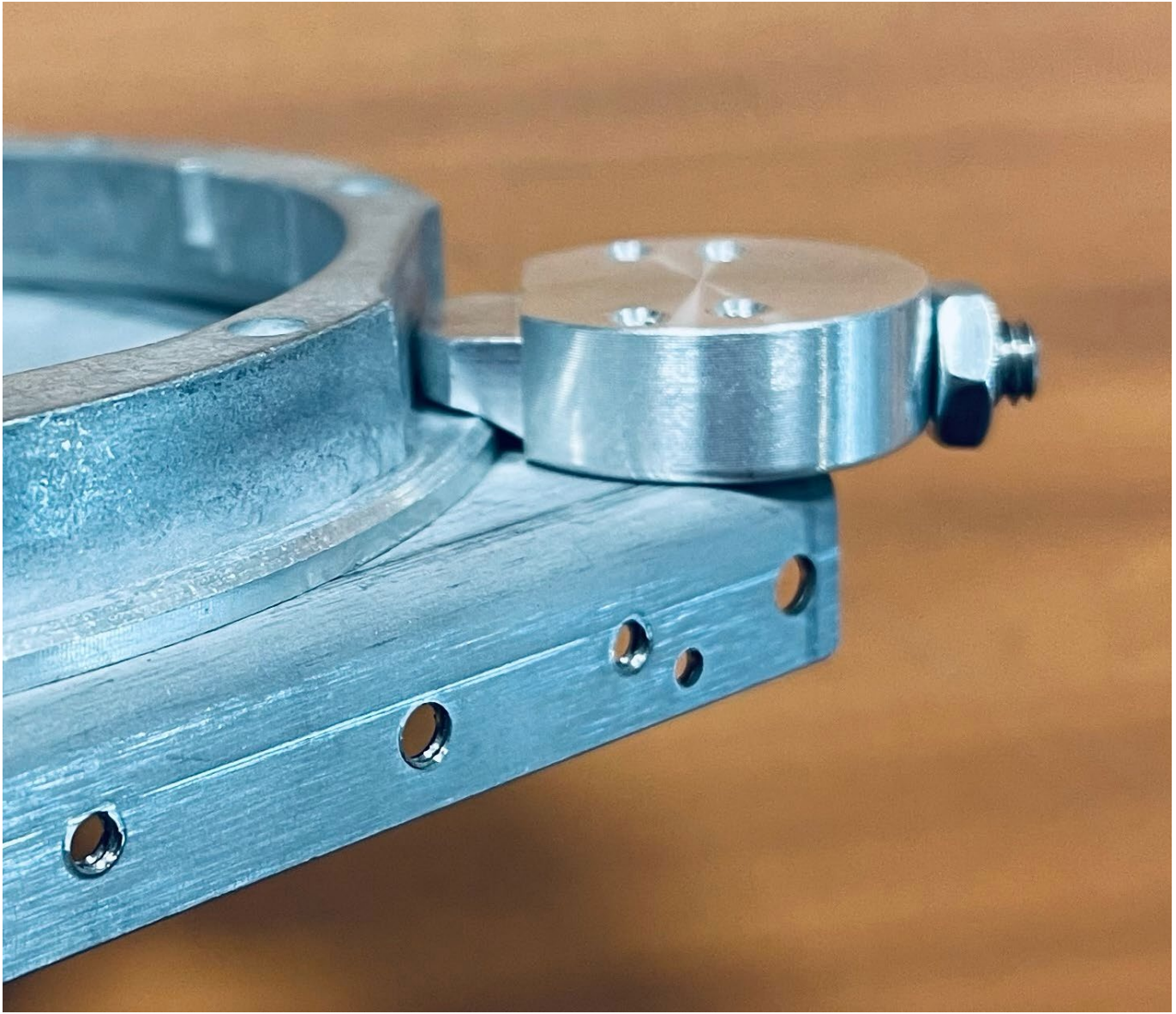

Figure 4 - Collimator Tube Mount Assembly Installation

PROPERLY SEATED MOUNTING LUG SLIDE ON FLANGE OF MOUNTING RING



****Hex Nut Shown is for CPL Models Only**

Figure 5 - Properly Seated Mounting Lug Slide on the Flange of the Mounting Ring

CML X-RAY TUBE MOUNTING ASSEMBLY

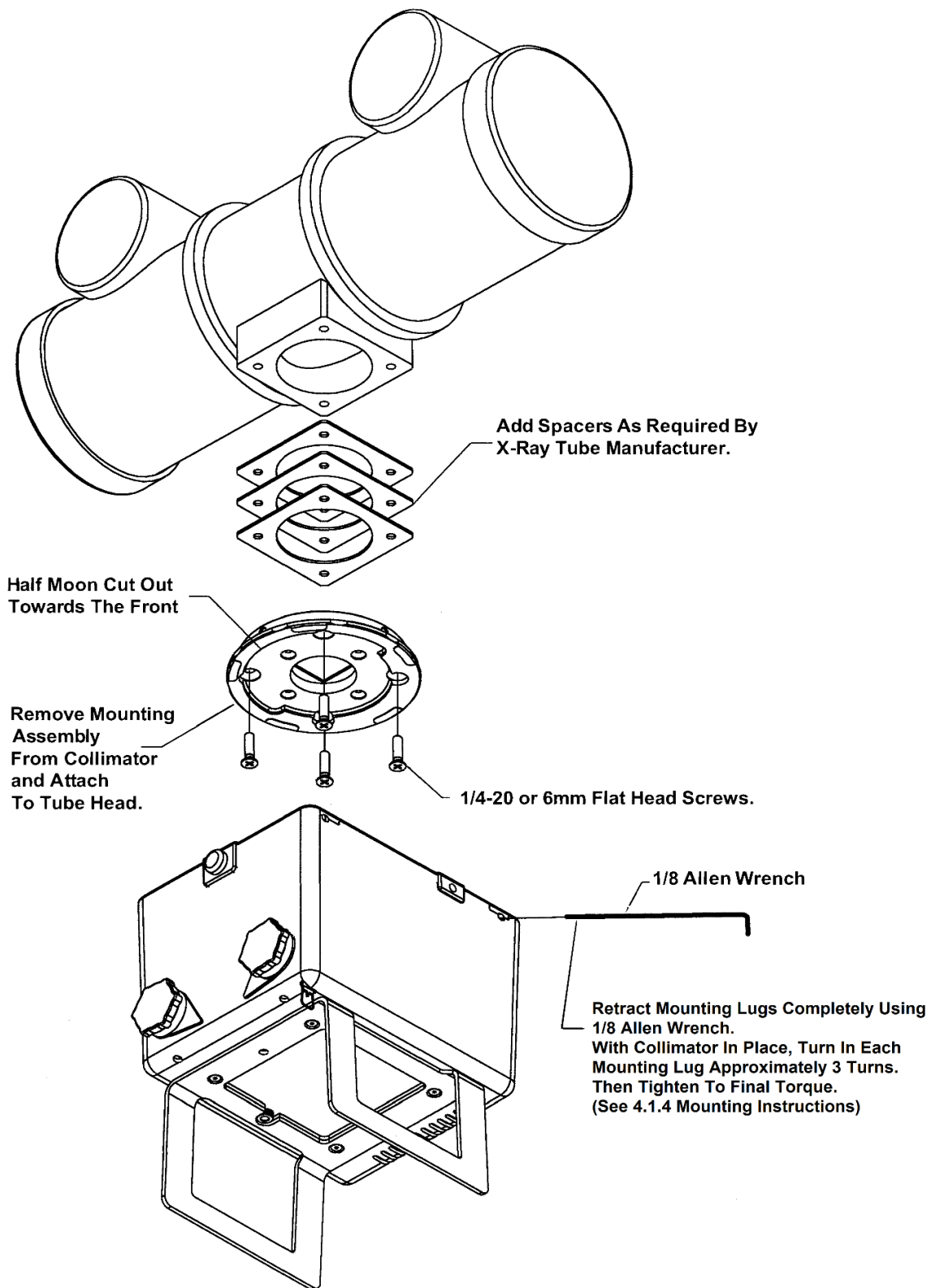

Figure 6 - CML X-Ray Tube Mounting Assembly

4.1.5 Mounting Instructions: Collimator to Portable X-Ray Unit

1. Refer to the collimator mounting instructions provided by the portable x-ray manufacturer before continuing with the following instructions. If instructions differ, follow the manufacturer's instructions.
2. The tube mount assembly for the collimator is shipped underneath the mounting lug slides on the top of the collimator. Remove the tube mount assembly by gently retracting the mounting lug slides fully (using a 1/8" Allen wrench) and lifting the tube mount assembly out.
3. With the tube mount assembly removed, gently extend one of the mounting lug slides back out by turning the screw (which is on the inside of the mounting lug) clockwise with the same Allen wrench. Gently tug on the mounting lug slide while it is turning. When the mounting lug slide comes free of the interior screw, simultaneously remove the mounting lug slide and stop turning the screw.
4. With the mounting lug slide removed, apply a small amount of Blue Loctite (243) to the interior of the threaded hole on the mounting lug slide.
5. Place the mounting lug slide back onto the end of the screw it was removed from. Gently apply pressure to the mounting lug slide while starting to turn in the opposite direction (counter-clockwise) until the mounting lug slide is fully seated back into the mounting lug.
6. Repeat steps 2 through 4 for the other three mounting lug slides.
7. Mount the tube mount assembly onto the mono-block. Place the collimator up onto the tube mount assembly carefully such that the mounting ring is not pushed up, moved out of place, or angled. Mounting spacers can be placed in between the top of the mounting ring and the bottom of the mono-block to help make sure the mounting ring does not get accidentally pushed up.
8. Locate once again the interior screw of each mounting lug slide. Turn each of these screws roughly three revolutions to push each of the mounting lug slides out. This will help to center the collimator on the mounting ring. (If each mounting lug slide is not able to screw in at least three revolutions, then the mounting ring is not in the proper position. If this is the case, you will need to unscrew the mounting lug slides and check the positioning of the mounting ring.)
9. Confirm once more that the mounting ring is level, nearly flush with the top of the collimator top cover. Make sure that the mounting ring is not angled, uneven, or resting above the top cover of the collimator after mounting. If the mounting ring is not mounted properly, the mounting lug slides may not seat into the correct positions on the mounting ring. Instead, they may latch onto the outer diameter of the mounting ring and may ride up or over the flange (or lip) of the mounting ring. If this were the case, the collimator would feel tight at first but could become loose and potentially fall off later. See Figure 7, page 20 for a visual reference of how the mounting lug slide should be seated over the top flange of the mounting ring.
10. FLOATING MOUNT STYLE ONLY - Align the center of the collimator with the center of the x-ray field by adjusting the mounting lug slides as needed.
11. Once the collimator has been centered, use a torque screwdriver to apply torque incrementally up to 20 inch-pounds (2.26 Newton meters) to the mounting lug screws. For example, apply 10 in-lbs to each of the four mounting lug screws sequentially, then apply 15 in-lbs to each, then 20 in-lbs. With proper execution of this procedure, there should be only slight drag in the rotation of the collimator on the mounting ring. If the amount of drag is considered to be too much, then this step should be repeated using a lower torque value.
12. Tighten each of the four nuts located on the adjustment screws tight to each of the mounting blocks. (Figure 5, page 20)

CPL PORTABLE MOUNTING ASSEMBLY

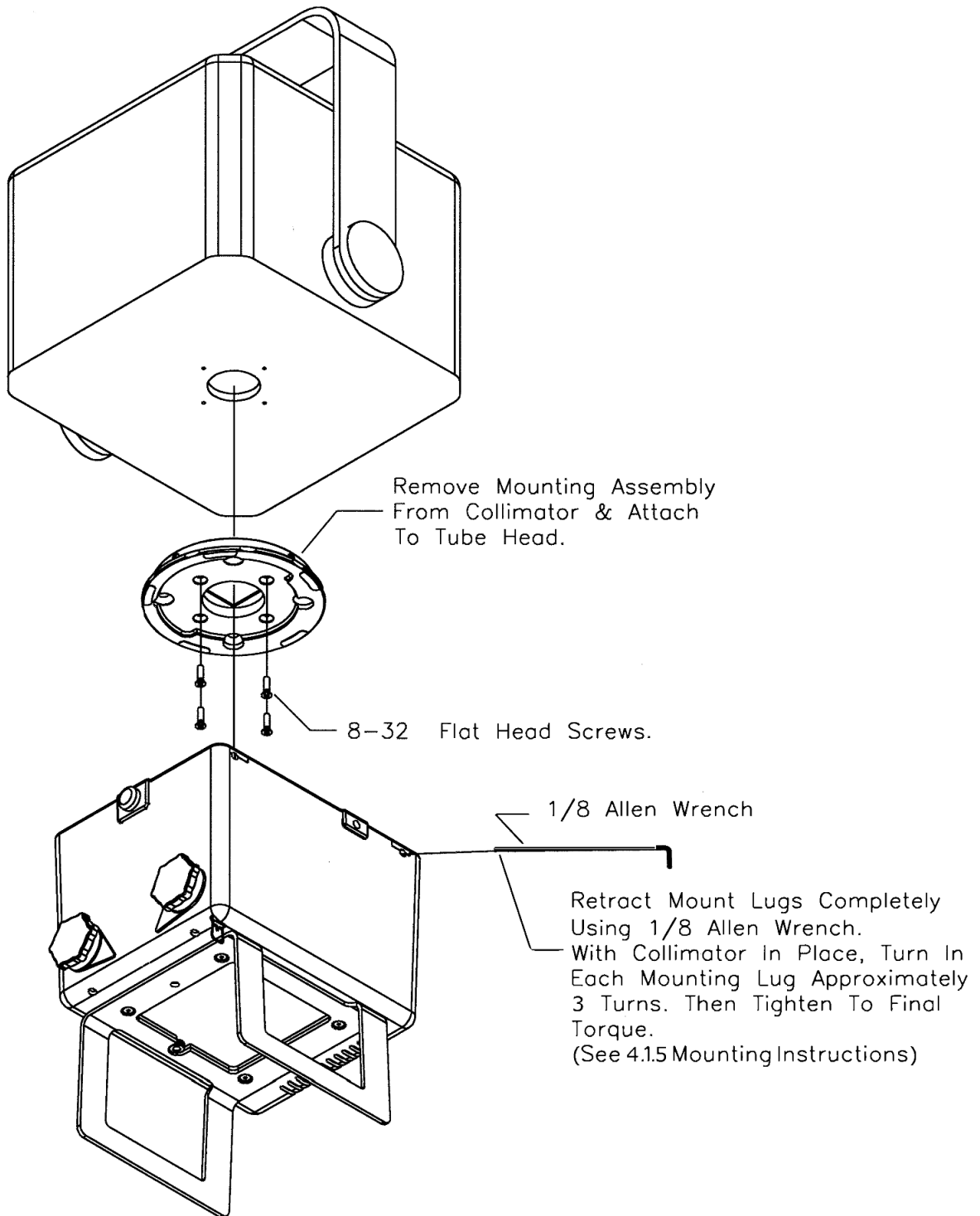

Figure 7 - Portable Head Mounting Assembly

4.2 ALIGNMENT OF X-RAY FIELD TO LIGHT FIELD

CAUTION: DO NOT REMOVE HOUSING TO ALIGN LIGHT FIELD OR LASERS.

The light field and lasers are aligned to the center of the collimator at the factory and should not require further adjustment.

The collimator mount is not adjustable for transverse or longitudinal alignment. Align the light field to match the x-ray field per the following instructions:

Carefully ensure that both the x-ray source/collimator assembly and target are properly leveled in x and y and that the SID is set at 40 inches (1 meter). Any error in x-ray source/collimator and/or target level/alignment will cause errors in the alignment procedure. A beam parallel tool will help establish proper alignment. Follow the manufacturer's instructions for use of the beam parallel tool.

1. Place a Collimator Test Target (shown below & provided in shipping box) on top of the x-ray cassette or image detector. Using the turn knobs, adjust the field size to 10in x 10in @ 40in SID.

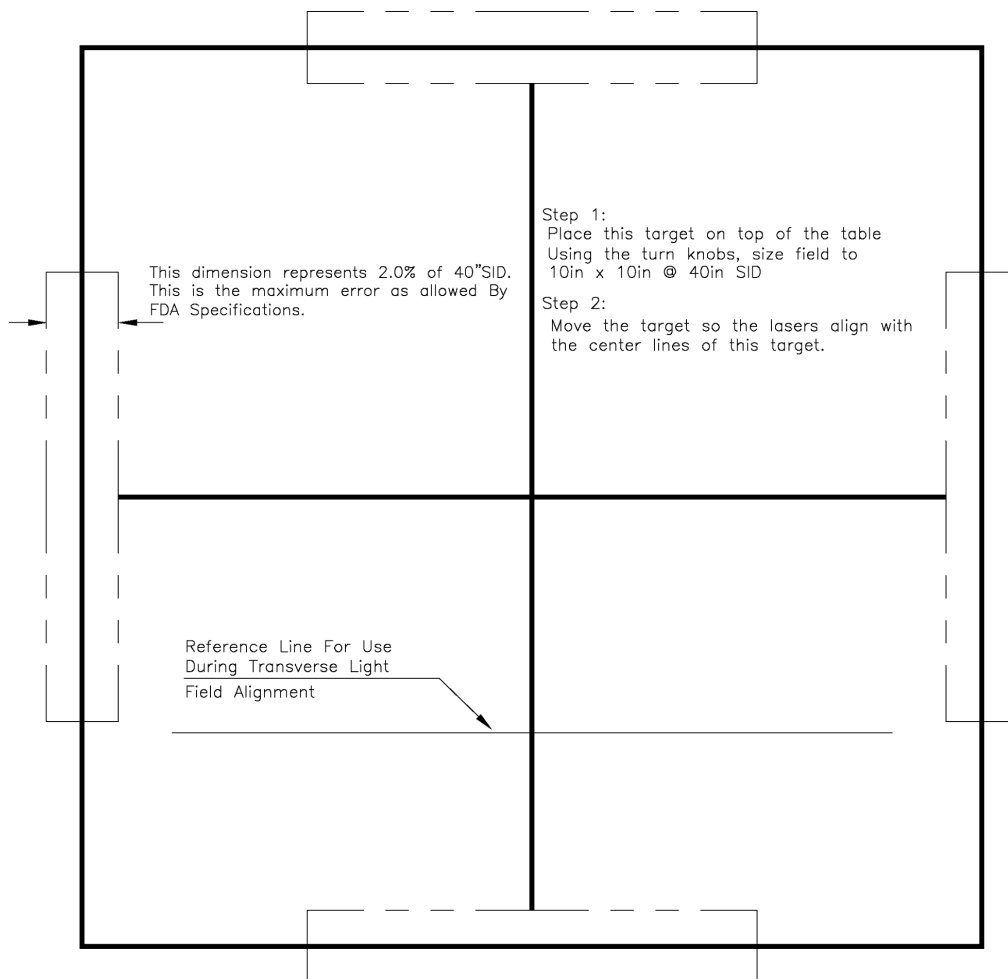

2. Turn on the collimator light/lasers and move the Collimator/X-ray Tube Assembly so the lasers align with the center lines of the target.
3. Take an appropriate exposure and compare the X-ray image to the light field.
4. If the x-ray to light field alignment is not satisfactorily within 2% of SID total error, per FDA allowance, then the light field alignment can be adjusted per section 4.3.1 Light Field Adjustment, page 25.

4.3 LIGHT AND LASER ADJUSTMENT

The following adjustment procedures are performed with the collimator located in a single fixed position above a test pattern located on the tabletop.

PLEASE NOTE: All Collimators have been completely tested and calibrated at the factory. Light and Laser Adjustment should only need to be performed to correct small changes in the light field or lasers due to shipping vibrations or slight differences in the X-Ray equipment. If the light field or lasers are way off, please ensure that the collimator is mounted correctly to the X-Ray tube.

EQUIPMENT REQUIRED:

- Collimator target sheet included with the collimator in the manual bag.
- Measuring tape or ruler.
- 10" x 10" X-ray film cassette.

4.3.1 Light Field Adjustment

This adjustment must be performed upon initial installation and when the internal collimator LED board is altered from its original position or is replaced.

Longitudinal Light Field:

To adjust the longitudinal light field, insert a 9/64 Allen wrench into the adjustment screw hole located on the left side of the collimator housing. Turn the wrench in the clockwise direction to move the field to the left.

Transverse Light Field:

To adjust the transverse light field, move the shutters to the following position:

- The longitudinal shutters to a field size greater than 12" at 40" SID
- The transverse shutters to the field size of 5" at 40" SID
- Insert a 9/64 Allen wrench into the adjustment screw hole located in the housing at the bottom front of the collimator. The adjustment hole is behind the front laser and allows access to the adjustment screw. Turn the wrench in the clockwise direction to move the field to the rear.

LIGHT FIELD ADJUSTMENT

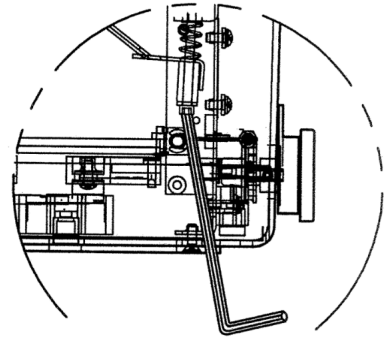
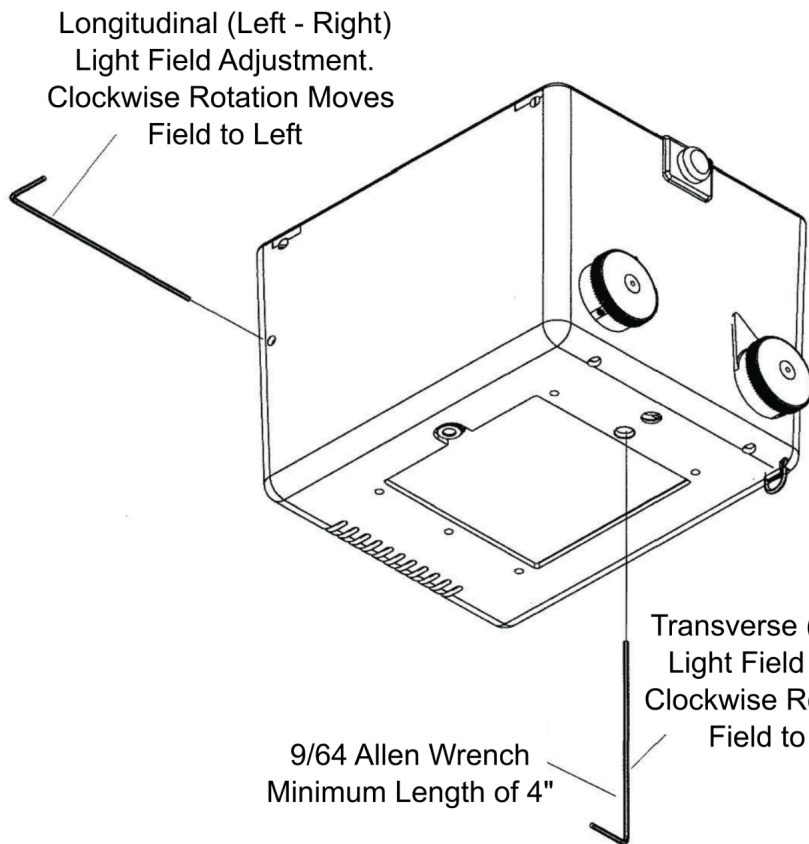

To Adjust Transverse Light Field,
Align Turn Knobs to 12" x 5"
at 40" SID.
Tilt Allen Wrench Towards
Front of Collimator.

Figure 8 - Light Field Adjustment

2.3.2 Internal Laser Adjustment (Collimators with Serial Numbers before A08323)

(Figure 9, page 29)

Remove the main Collimator housing per instructions (Figure 14, Page 38).

Laser Sweep:

The sweep of the laser line can be adjusted by loosening the two hex screws that hold the laser housing assembly tight to the collimator chassis. Once loose the housing can be rotated to adjust the sweep of the laser line. Once the line is in the desired position hold the housing in place and tighten the screws.

Laser Angle:

The angle of the laser line can be adjusted by loosening the set screw in the center of the laser housing that holds the laser tight. Once loose the laser module can be rotated with a pair of pliers or vice grips. Once the laser line is in the correct position hold the laser in place and tighten the set screw.

Once the lasers are in the correct position the collimator housing can be replaced.

4.3.3 External Laser Adjustment (Collimators with Serial Numbers after A08322)

(Figure 10, page 30)

These lasers can be adjusted externally and do not require the housing to be removed.

Laser Sweep:

The sweep of the laser line can be adjusted by rotating the laser assembly hex screw using a 9/64th Allen wrench.

Laser Angle:

The angle of the laser line can be adjusted by using a large flat bladed screw driving and inserting the blade into the slotted line in the laser cap. Carefully use the screwdriver to rotate the laser cap counterclockwise or clockwise depending on the direction of rotation needed.

INTERNAL LASER ADJUSTMENT
Internal Lasers - Collimators with S/N before A08323

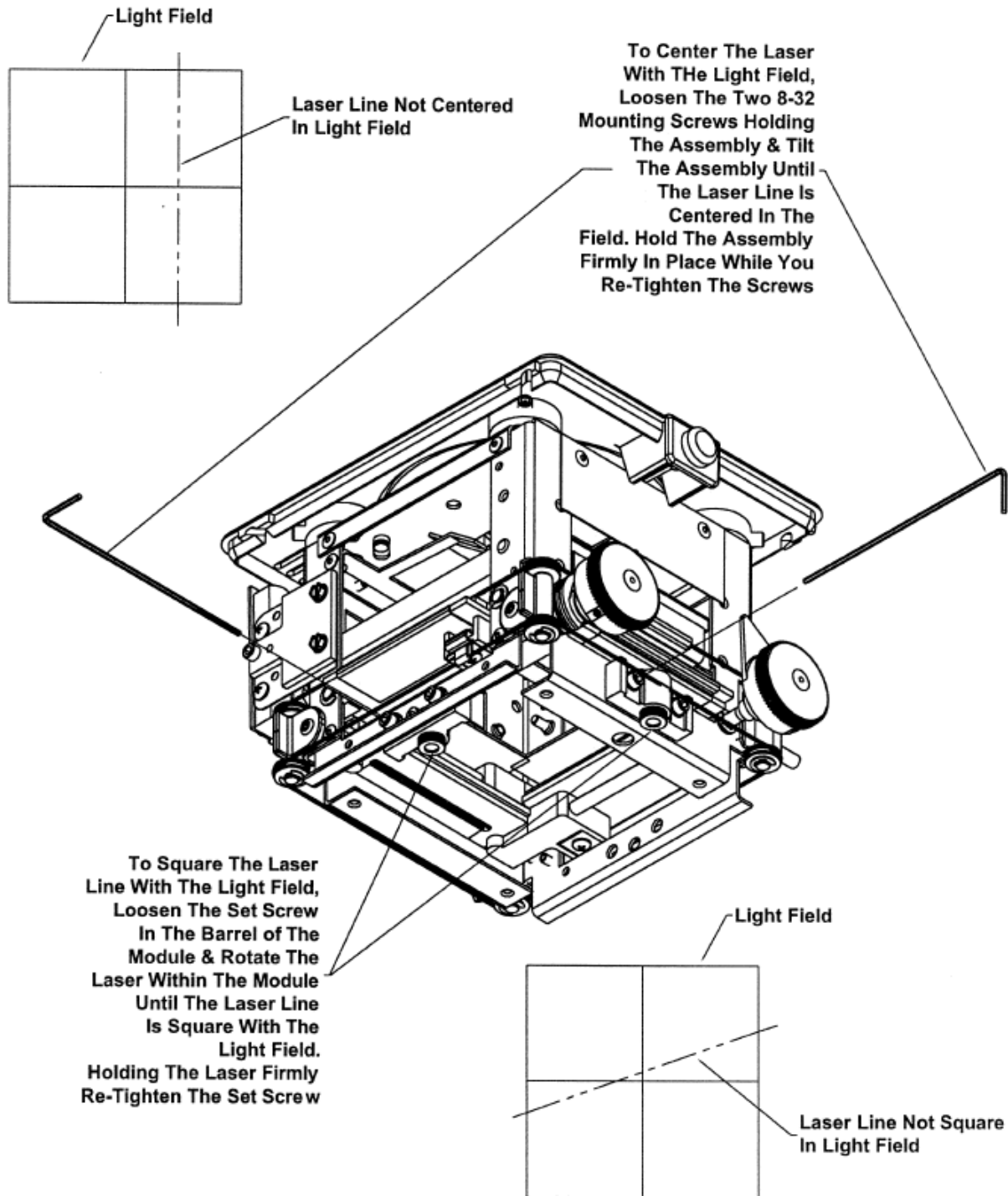

Figure 9 - Internal Laser Adjustment

EXTERNAL LASER ADJUSTMENT
External Adjustable Lasers - Collimators with S/N after A08322

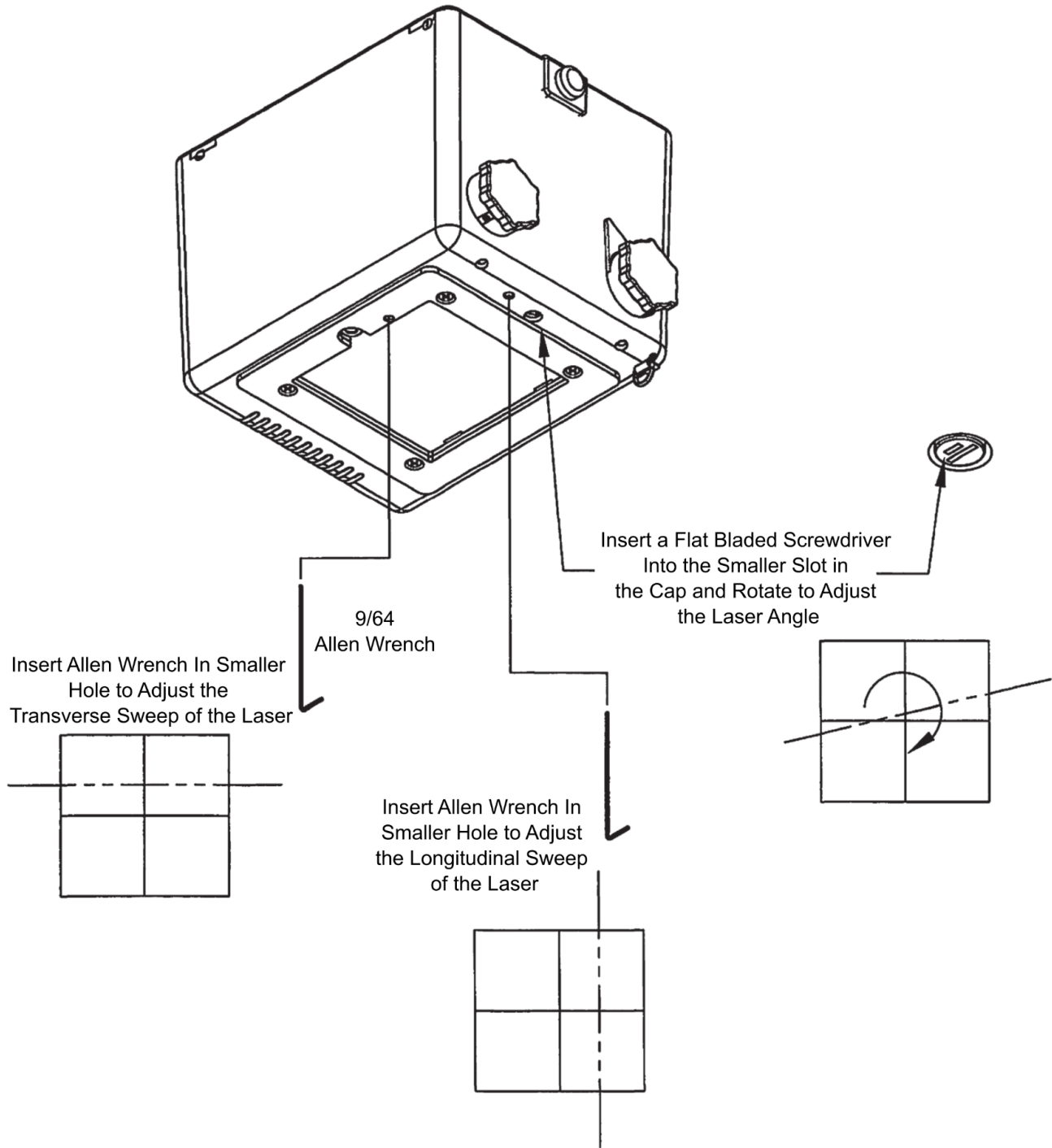

Figure 10 - External Laser Adjustment

4.4 ELECTRICAL CONNECTIONS

This is a **CLASS I** electrical device and must be wired in accordance with all applicable electrical codes and regulations. The power supply cable from the power supply to the Collimator must be sized to handle the full continuous rated load taking into consideration the distance from the collimator to the power supply.

Power Supply Requirement(s) (to comply with light output requirement):

LED Board Version A: 12VDC-24VDC & 24V Isolated AC 50/60Hz @ 1A - 2A. Not Polarized

LED Board Version B: 12VDC-24VDC & 24V AC 50/60Hz @ 1A-2A. Polarized

LED Board Version A Requires an isolated, primary and secondary fused AC transformer or DC power supply.

4.4.1 Confirming Isolated AC Power

1. Connect the supplied 25' extension cable Black and White wires to your AC Source.
DO NOT PLUG INTO THE COLLIMATOR PIGTAIL YET! Attach Green wire to ground.
2. With a voltmeter, measure the Black wire to the Green Wire. It should read approximately 10-50VAC. If it reads zero (0) VAC, the power is not isolated and cannot be used!
3. With a voltmeter, measure the White wire to the Green Wire. It should read approximately 10-50VAC. If it reads zero (0) VAC, the power is not isolated and cannot be used!
4. With a voltmeter, measure the Black wire to the White wire. It should read approximately 24VAC.

If you measure 24VAC, after performing the individual tests as above, you have isolated AC and can use this source to power the collimator.

4.4.2 LED Replacement

The LED is part of the circuit board assembly and must be replaced as a whole.

4.4.3 LED Board Assembly Replacement

1. Remove the collimator knobs (Figure 13, page 37) and the housing (Figure 14, page 38)
2. Remove the current LED board from the chassis by unscrewing the four screws that hold the circuit board assembly to the two aluminum mounting posts (Figure 16, page 40)
3. Remove the 6 pin and 8 pin connectors from the current board. These pull straight up. Do not unscrew the terminals holding the wires in place.
4. Take the new LED board and seat the 6 pin and 8 pin connectors onto the adapter board pins in the exact pin positions they were removed from. Correct position does matter.
5. **Note:** LED Board Version B requires the correct polarity. Check the power wires and swap them if needed. If the unit has a Power Conditioning Board, then Red is +PWR (Pin 2) and Black is 0V Return (Pin 1). If the unit does not have a Power Conditioning Board and instead is directly wired to the power pigtail then Blue is +PWR (Pin 2) and Brown is 0V Return (Pin 1).
6. Mount the new board back on the chassis by reversing steps 1 and 2.

4.4.4 External 25' Power Interface Cable

CAUTION! The 25' Interface Cable May Use Different Wire Color Codes. Refer to Collimator 25' Interface Cable Wiring Diagram on page 34 for more information.

Table Lock Switch Function:

Light Field/Lasers come on and self-timeout after the default on time or they can be turned off immediately by pressing the Front Button.

Remote Switch Function:

Light Field/Lasers come on with a switch press and turn off with a switch press. Remote Switch mimics the collimator Front Button and functions.

COLLIMATOR LED BOARD VERSION A WIRING DIAGRAMS

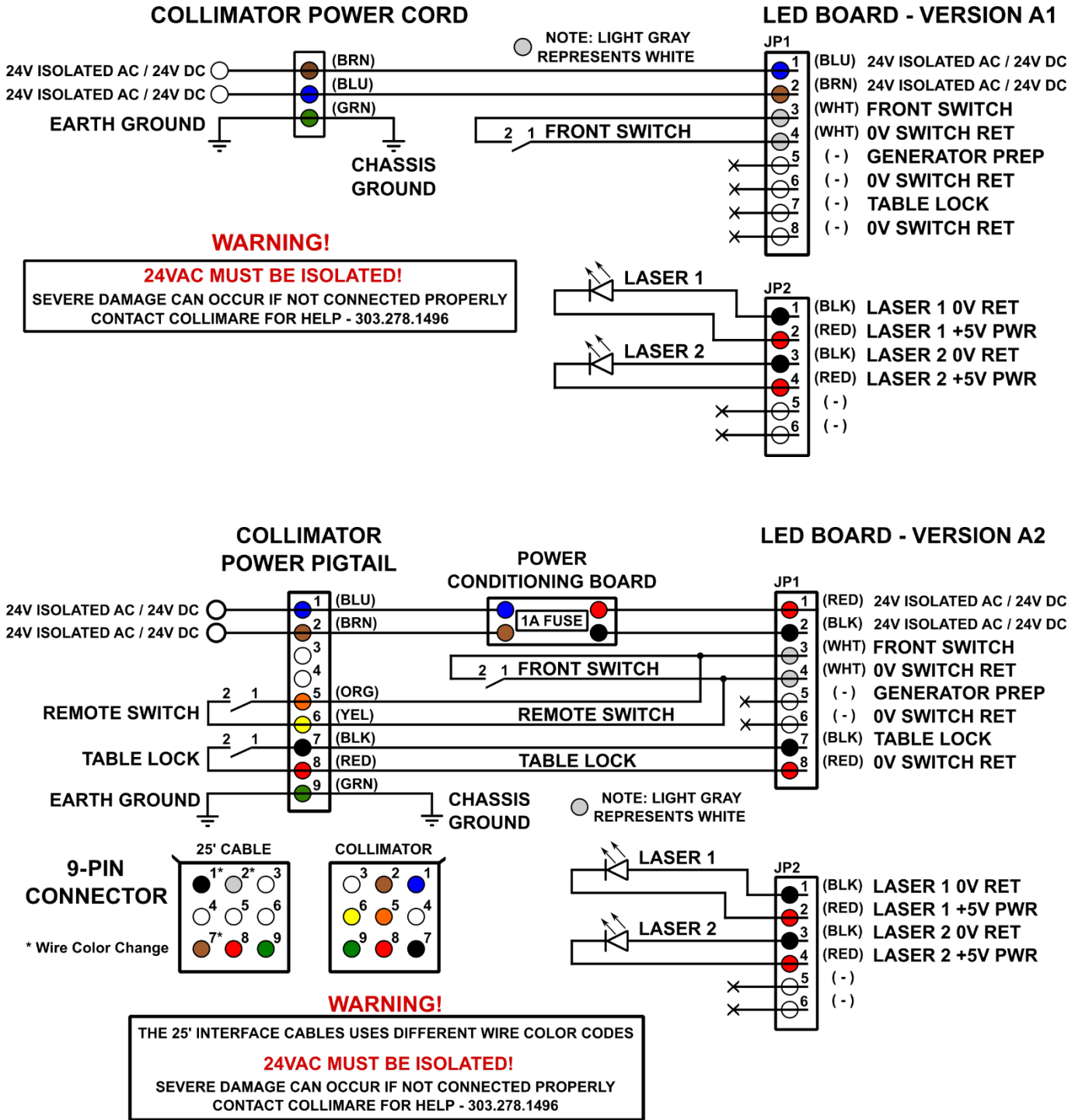

Figure 11 - LED Board Version A Wiring Diagrams

COLLIMATOR LED BOARD VERSION B WIRING DIAGRAMS

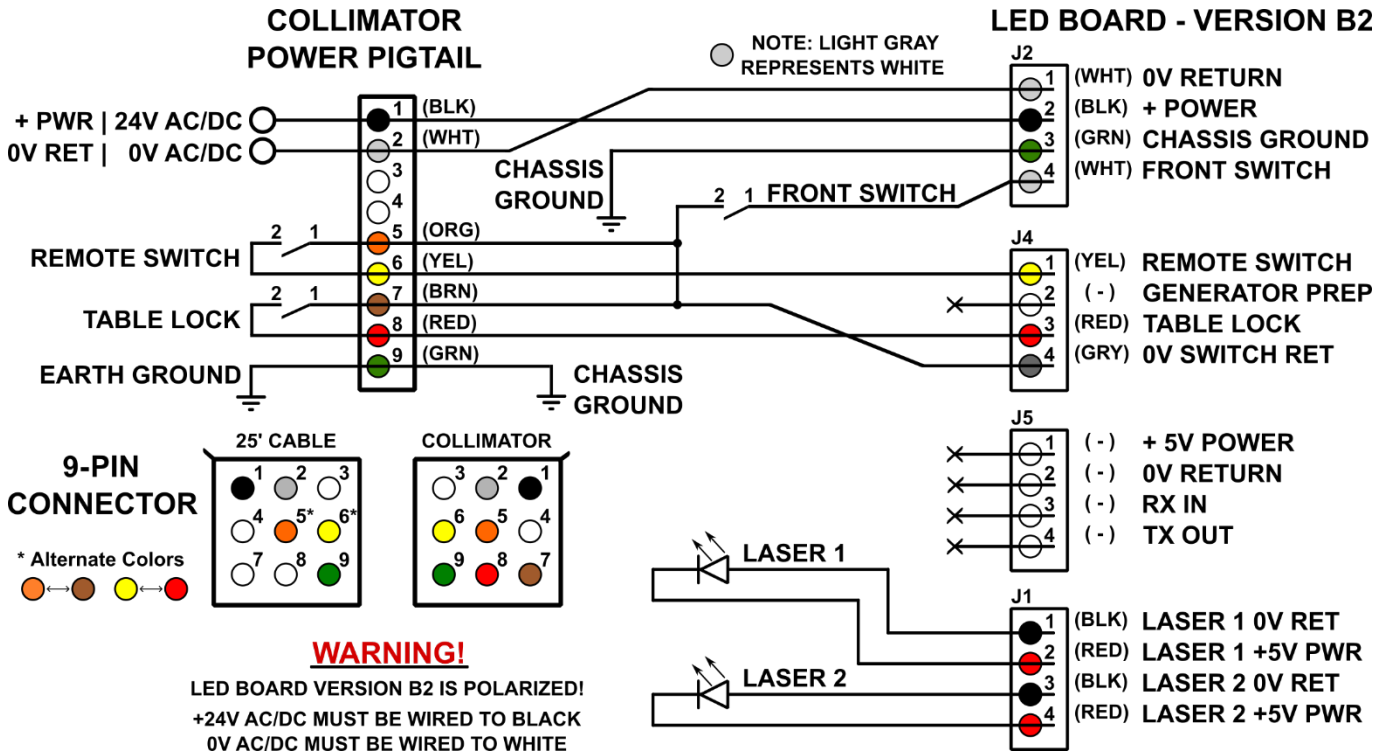
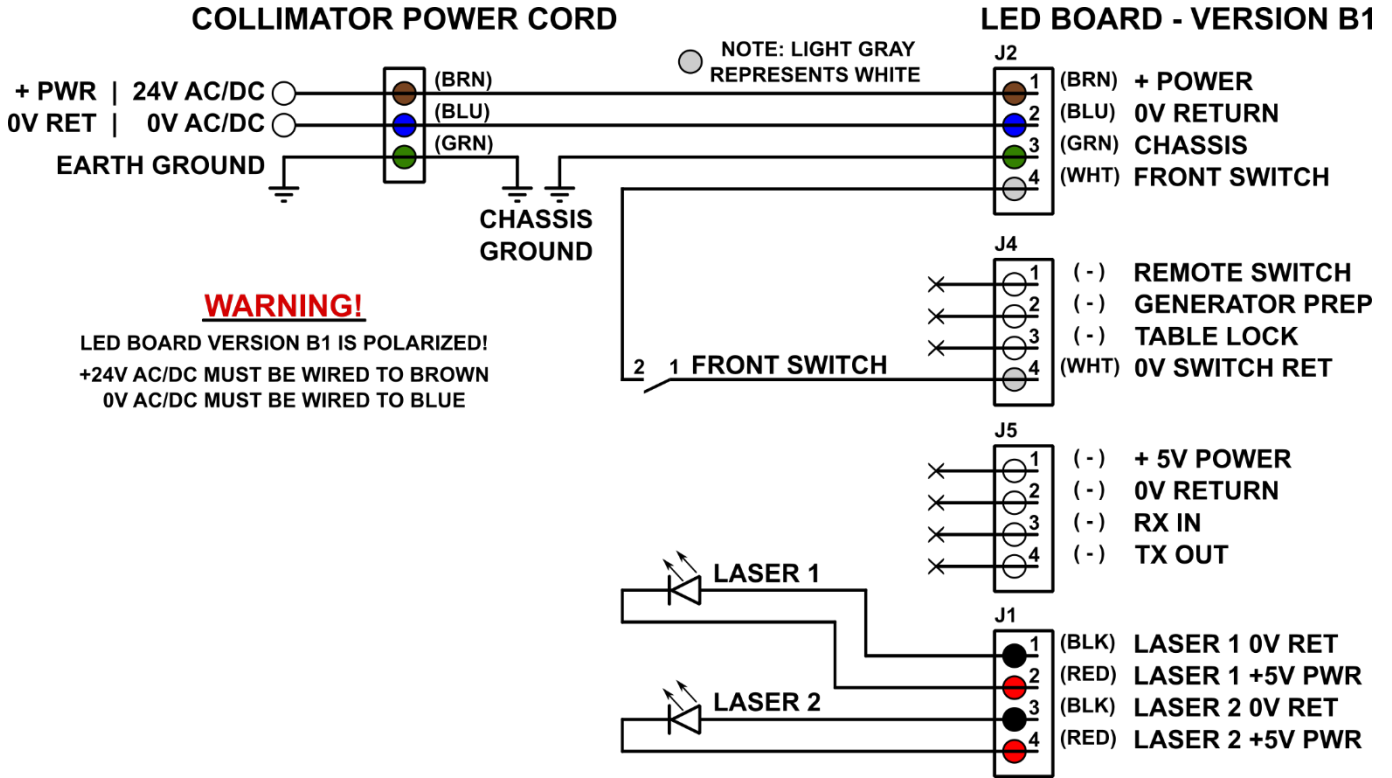
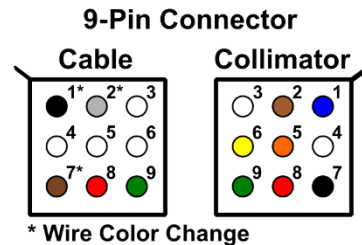
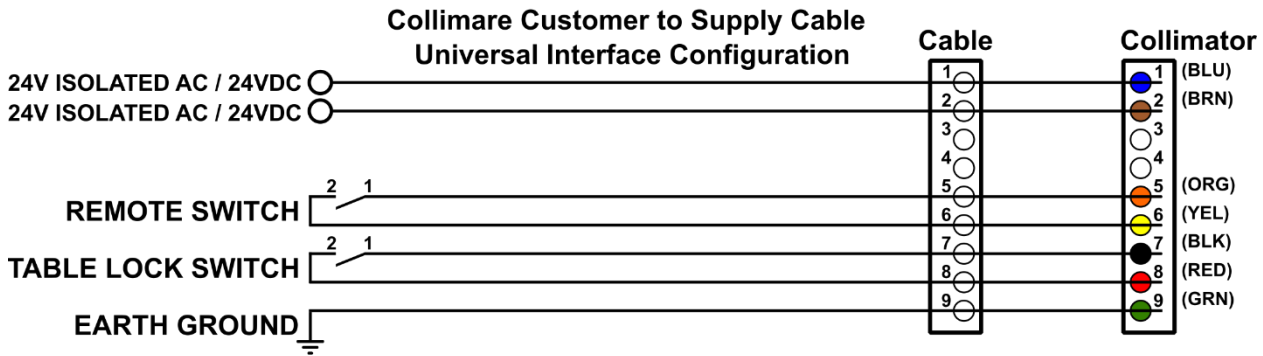
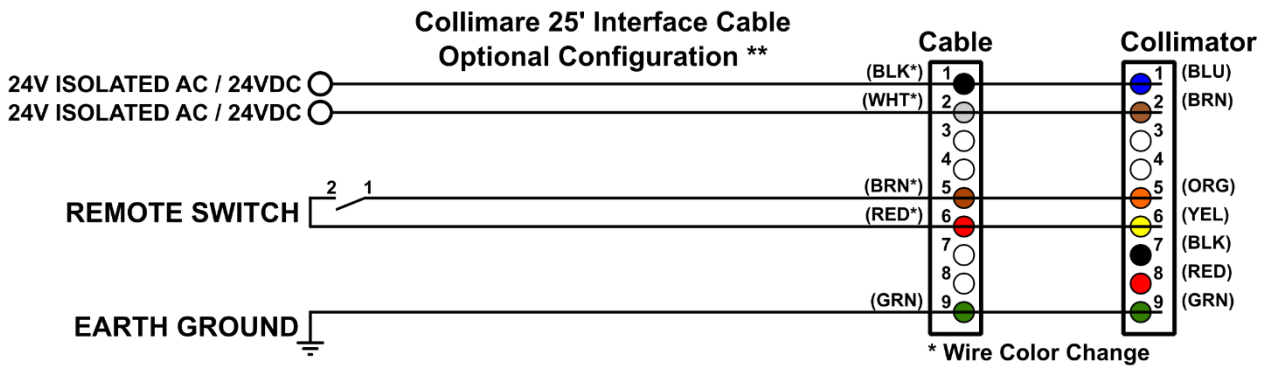
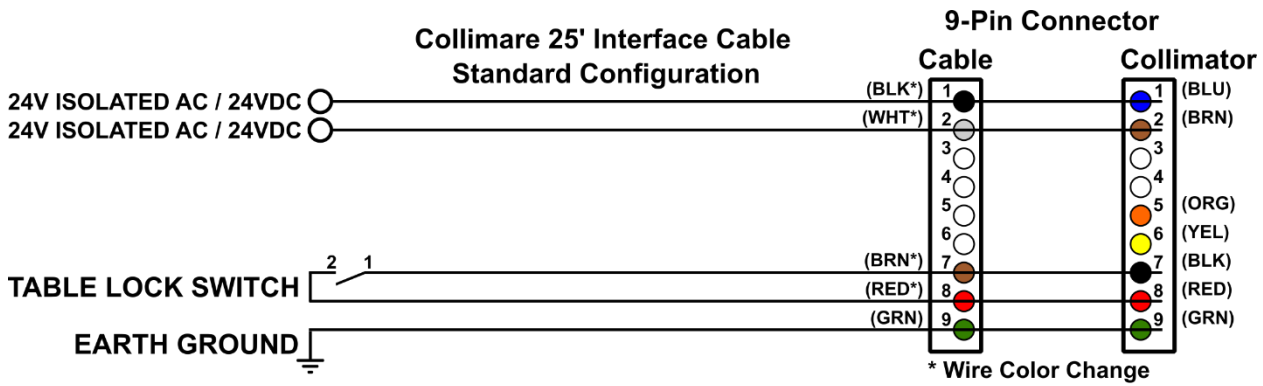

Figure 12 - LED Board Version B Wiring Diagrams

4.4.5 Collimator 25' Interface Cable Wiring Diagram – Version A



CAUTION! The 25' Cable Uses Different Wire Color Codes.

Optional Configuration – Enabling Remote Switch:

Remove the External Switch Wires (Pins 7 and 8) from the 9-Pin Connector and insert them into Pins 7 and 8.

Board Polarity:

LED Board Version A is not polarized and +PWR can wire into Pin 1 or Pin 2.

Power Requirements:

LED Board Version A must be powered by either **24VDC or ISOLATED 24V AC**. For best results use a dedicated 24VDC supply to power only the collimator.

4.4.6 Collimator 25' Interface Cable Wiring Diagram – Version B

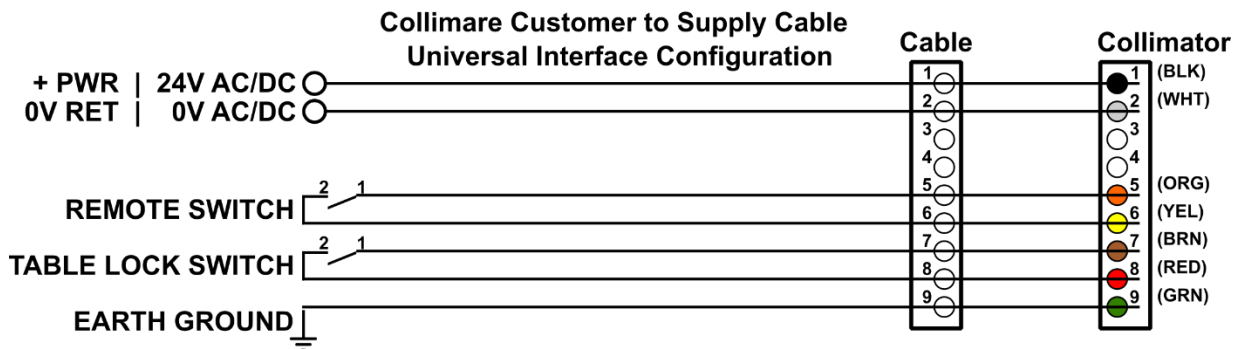
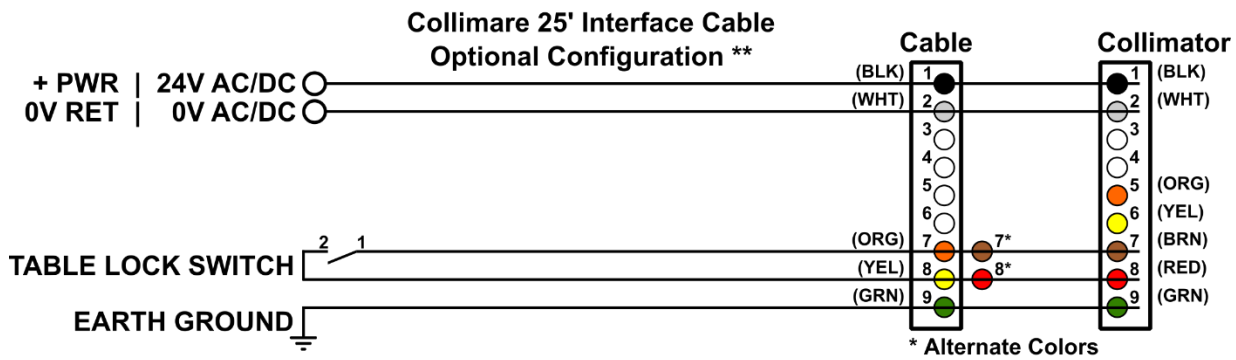
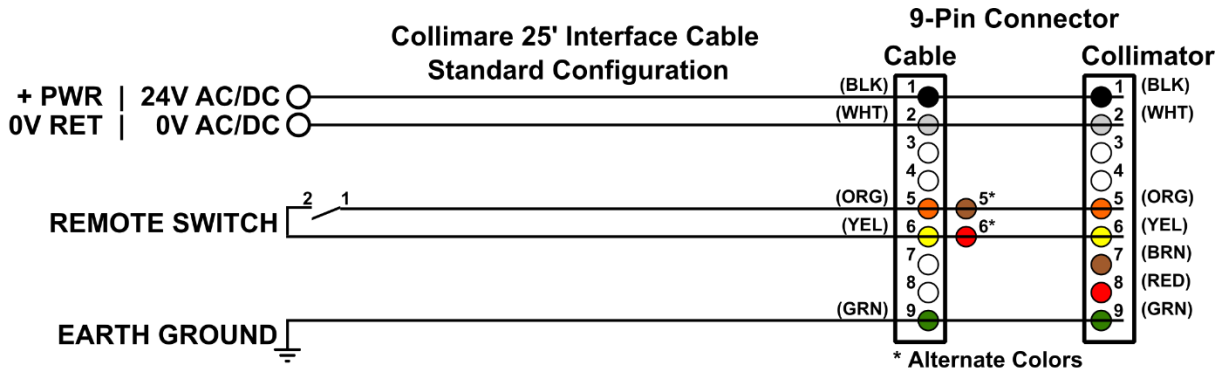

9-Pin Connector

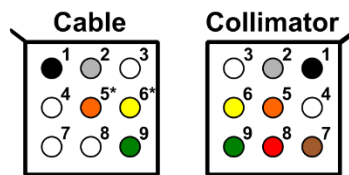

*Alternate Colors



Optional Configuration – Enabling Table Lock:

Remove the External Switch Wires (Pins 5 and 6) from the 9-Pin Connector and insert them into Pins 7 and 8.

Board Polarity:

CAUTION! LED Board Version B is polarized.

+24V PWR must be wired to Black (Pin 1).

0V RET must be wired to White (Pin 2).

Alternate Wire Colors:

Some 25' Interface Cables will have Red and Brown wires instead of Yellow and Orange.

5.0 SERVICE INSTRUCTIONS

This section contains the following illustrated instructions for servicing the collimator:

5.1 - KNOB REMOVAL

Figure 13 - Page 37

5.2 - HOUSING REMOVAL

Figure 14 - Page 38

5.3 - SKIN GUARD REMOVAL

Figure 15 - Page 39

5.4 - LED BOARD REPLACEMENT

Figure 16 - Page 40

5.5 - LIGHT FIELD ADJUSTMENT

Figure 8 - Page 27

5.6 - INTERNAL LASER ADJUSTMENT

Collimators with Serial Numbers less than A08323

Figure 9 - Page 29

5.7 - EXTERNAL LASER ADJUSTMENT

Collimators with Serial Numbers greater than A08322

Figure 10 - Page 30

5.1 - KNOB REMOVAL

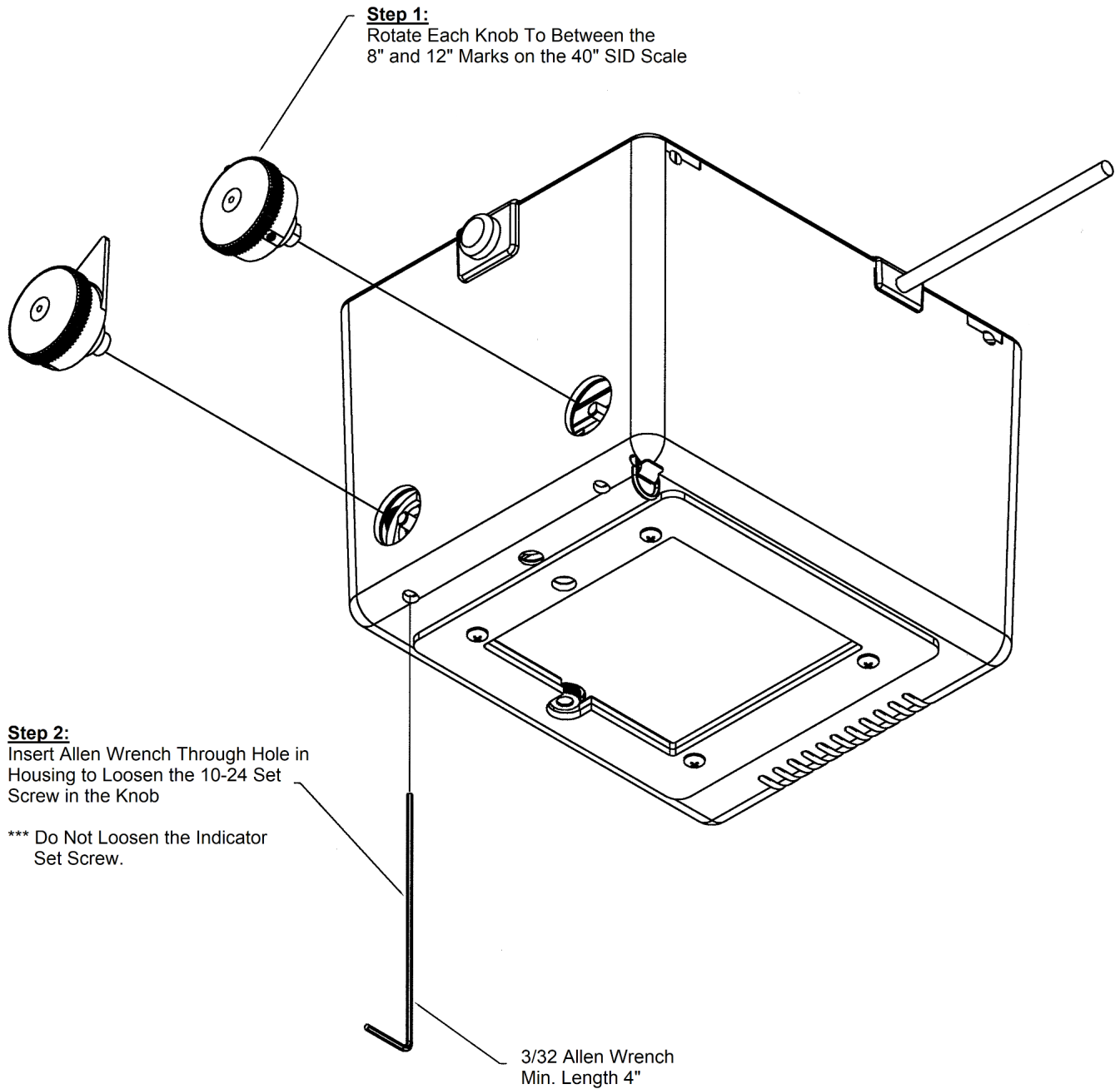
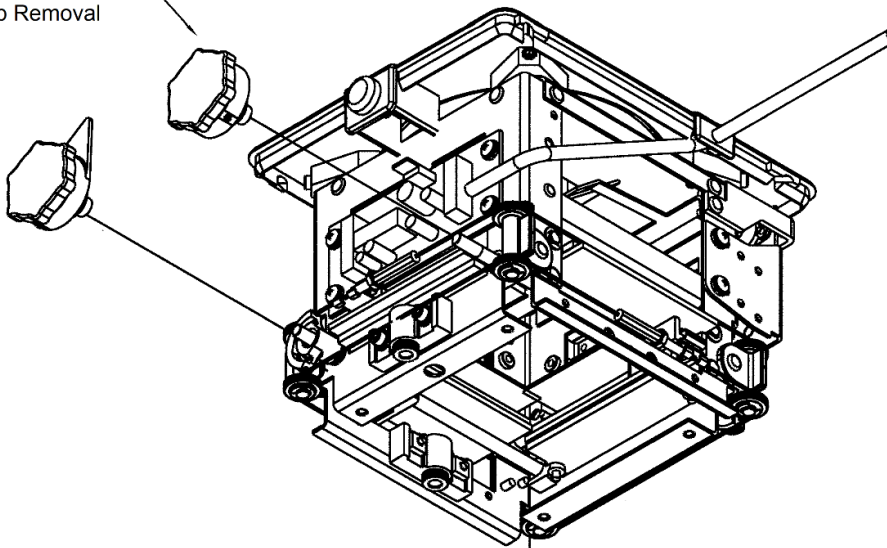

Figure 13 - Knob Removal

5.2 - HOUSING REMOVAL

Step 1:

Remove the Knobs. Refer to Figure 13 - Knob Removal on Page 33



Step 2:

Remove the 8-32 Screws To Drop Housing From Chassis.

Step 3:

The Housing Is A Close Fit.

Angle the Housing to Clear The Knob Shafts.

Use Caution As You Remove The Housing To Clear Internal Mechanisms.

Figure 14 - Housing Removal

5.3 - BEZEL / SKIN GUARD REMOVAL

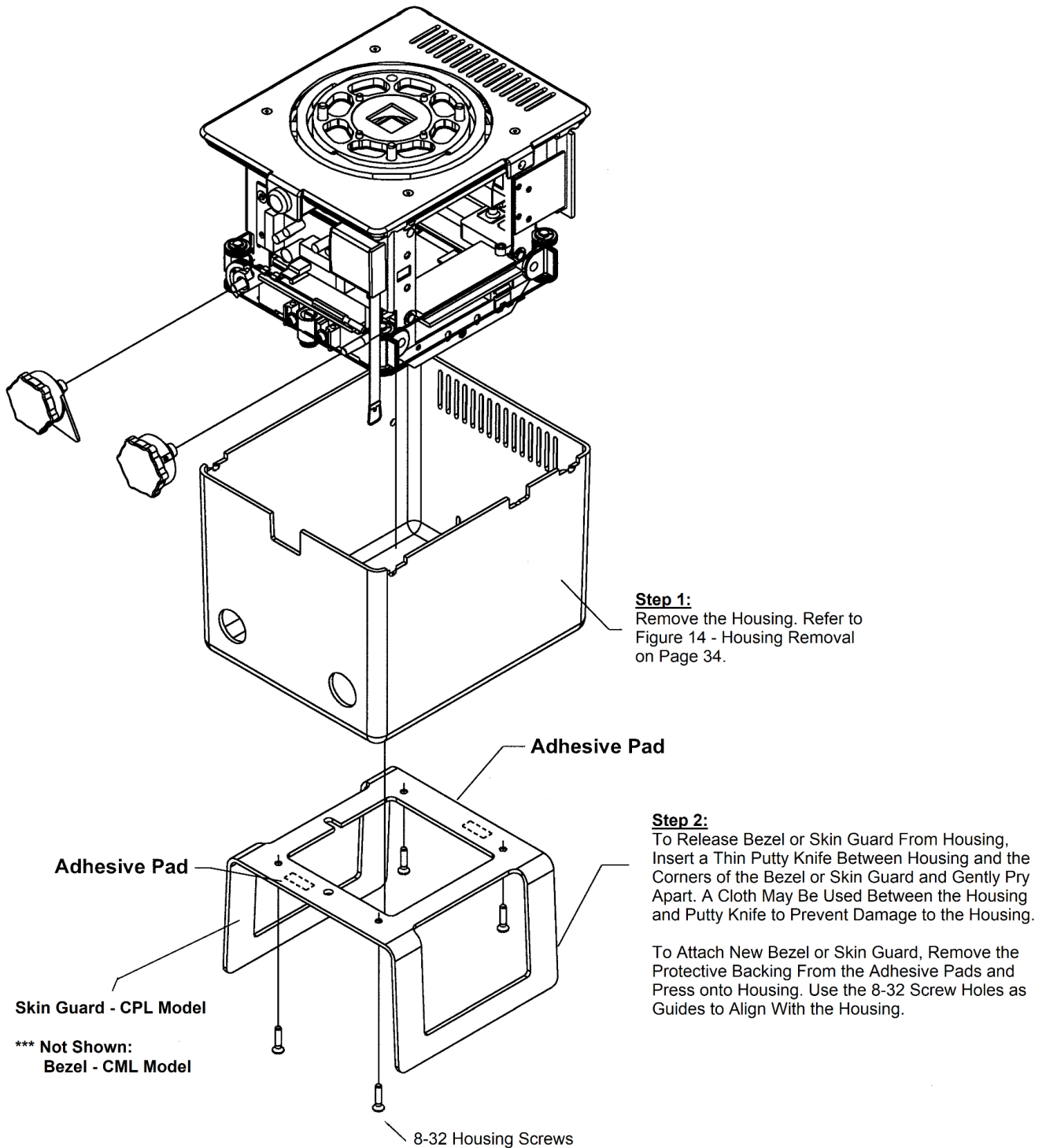

Figure 15 - Bezel / Skin Guard Removal

5.4 - LED BOARD REPLACEMENT

Follow the numbered instruction steps in order

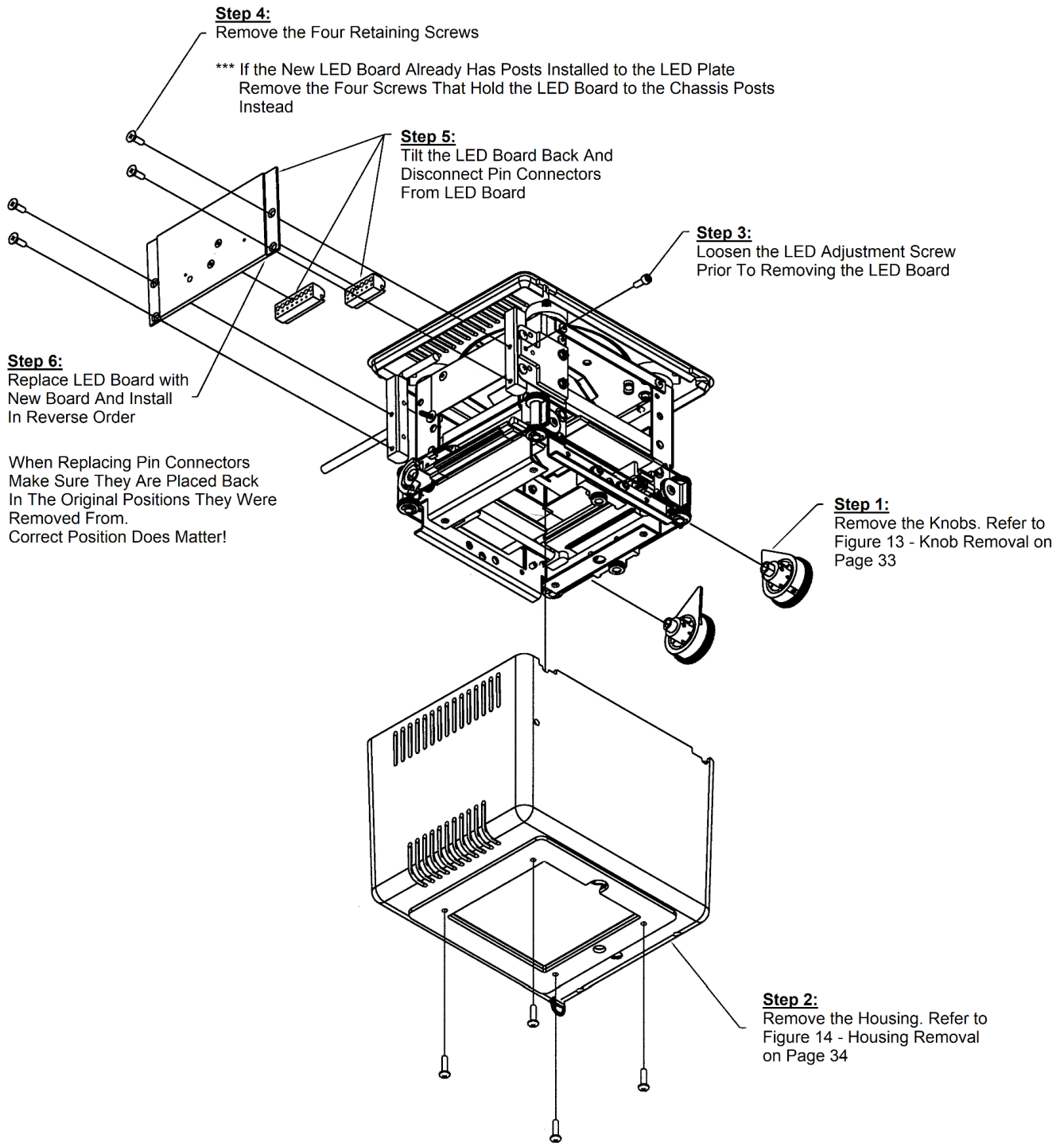

Figure 16 - LED Board Replacement

6.0 REPLACEMENT PART LISTING

P/N	Description	Notes to Consider
	Tube Mount	
CM-11-0021-2B	Assembly, Tube Mount, CM	<i>Includes the Mounting Collar</i>
CP-11-0021-4A	Assembly, Tube Mount, CP	<i>Includes the Mounting Collar</i>
CP-11-MX21-3A	Assembly, Tube Mount, MinXRy	<i>Includes the Mounting Collar</i>
CP-11-MX21-2B	Assembly, Tube Mount, MinXRy, Old Floating Style	<i>Includes the Mounting Collar smooth ring, no posts</i>
CP-11-SR21-3A	Assembly, Tube Mount, SourceRay, Old Floating Style	<i>Includes the Mounting Collar smooth ring, no posts</i>
CM-12-0018-1D	Mounting Collar	<i>Only Sold as Part of Tube Mount Assembly</i>
CM-12-MX18-1A	Mounting Collar, MinXRy	<i>Only Sold as Part of Tube Mount Assembly</i>
CP-12-0018-2E	Mounting Collar, Old Floating Style	<i>Only Sold as Part of Tube Mount Assembly</i>
CP-12-MX18-3B	Mounting Collar, MinXRy, Old Floating Style	<i>Only Sold as Part of Tube Mount Assembly</i>
CM-12-0117-1B	Tube Mount Lead Seal	
CP-12-0115-1A	.25mm Aluminum Filter	<i>Sold as Packages of 5</i>
CM-12-0123-1B	Mounting Spacer, 0.06	
CM-12-0162-1A	Plate, Tube Mount Retaining/Spacer	
	Housing	
CM-11-0128-1B	Assembly, Housing, Beige	<i>Includes: Lead, Output Window, Bezel, Tape Measure, Overlay</i>
CP-12-0171-1A	Assembly, Housing, White	<i>Includes: Lead, Output Window, Bezel, Tape Measure, Overlay</i>
CP-11-SR05-1F	Assembly, Housing, SourceRay	<i>Includes: Lead, Output Window, Bezel, Tape Measure, Overlay</i>
CP-11-MX05-1H	Assembly, Housing, MinXRy (w/ skin guard)	<i>Includes: Lead, Output Window, Skin Guard, Angle Indicator, All Overlays, Tape Measure</i>
CM-11-0004-1B	Assembly, Tape Measure, CM	

CP-11-0004-1B	Assembly, Tape Measure, CP	
CP-11-SR04-1B	Assembly, Tape Measure, SoureRay	
CP-11-0080-1C	Assembly, Output Window	
CM-11-0120-1D	Assembly, Output Window Bezel	
CP-11-0007-1D	Assembly, Skin Guard	
	Top Cover	
CP-12-0006-1A	Top Cover, Beige	
CM-11-0006-1A	Assembly, Top Cover, Beige	<i>Includes the switch</i>
CP-12-0172-1A	Top Cover, White	
CP-11-0127-1A	Assembly, Top Cover, White	<i>Includes the switch</i>
CP-12-MX06-1A	Top Cover, Black, MinXRay	
CP-11-MX06-1A	Assembly, Top Cover, Black, MinXRay	<i>Includes the switch</i>
CP-13-0006-1A	Lamp/Laser Switch with 15in. Leads (22awg)	
	Electrical Cord	
CP-13-0045-1A	Cord, Electrical Supply, 34", 3 Cond	
CM-11-0046-1B	Assembly, 34" Power Cord, 3 Pin Connector	
CM-11-0134-1A	Assembly, 34" Power Cord, 9 Pin Connector	
CM-11-0047-1B	Assembly, 25' 3 Cond Interface Cord, 3 Pin Connector	
CM-11-0121-1A	Assembly, 25' 5 Cond Interface Cord, 9 Pin Connector	
CM-11-0135-1A	Assembly, 50' 5 Cond Interface Cord, 9 Pin Connector	
CML-13-0001	24VDC Power Supply with 110 AC Power Cord	
	Turn Knob	

CM-11-0002-1A	Assembly, Turn Knob, Aluminum	<i>CM/CML Greater than S/N: A04585 CP/CPL Greater than S/N: A04622</i>
CP-99-0034-1A	Turn Knob, Gray Plastic	<i>CM/CML Less than S/N: A04586 CP/CPL Less than S/N: A04623</i>
CM-11-0060-1A	Assembly, Turn Knob Black Cap, Gray Plastic Core	No Longer Stocked <i>Replace with CP-99-0032-1A</i>
CM-11-0119-1A	Indicator Assembly, Aluminum (Aluminum Hub, Acrylic Indicator)	<i>Used on all knobs</i>
CP-12-0036-1B	Indicator, Turn Knob (Machined)	No longer stocked. <i>Replace with CM-11-0119-1A</i>
CP-17-0036-1A	Indicator, Turn Knob (as molded)	No longer stocked. <i>Replace with CM-11-0119-1A</i>
Overlay		
CM-16-0096-1A	Overlay, LED Face Plate	
CM-16-0097-1A	Overlay, LED Face Plate, Metric	
CM-16-0098-1A	Overlay, LED Face Plate, 38in SID	
CM-16-0100-1B	Overlay, LED Face Plate, Metric, White	
CM-16-0082-1B	Overlay, LED Face Plate, 60in SID	
CP-16-MX82-1A	Overlay, MinXRy Scale Side	
CP-16-MX83-1A	Overlay, MinXRy Front Face	
CP-16-MX84-1A	Overlay, MinXRy Blank Side	
CP-16-SR90-1B	Overlay, SourceRay	
CT-16-0096-1E	Overlay, Touch	
Accessory		
CM-11-0122-1B	Kit, External Lead Weight	<i>Adds Approx 10 lbs</i>
CM-10-1001-1B	Kit, Accessory Rail	<i>Includes Hardware</i>
CM-10-1002	Kit, DAP Meter Rail	<i>Includes Hardware</i>
Chassis		

Factory Only	Internal Shutter/Cable Repair	<i>Collimator has to be returned to factory</i>
CP-11-0011-1E	Assembly, Mounting Lug	
CP-12-0035-1E	Drive Cable	
CP-12-0040-1C	Transverse Cable Clamp	
CP-12-0041-2B	Longitudinal Cable Clamp	
	Mirror	
CP-12-0042-1A	Mirror, 3" x 3" x 1.6mm BV-2 FS	
CP-14-0009-1A	Spring Clip, Mirror Retaining	
	Laser	
CP-12-0047-2A	Laser Module Housing	<i>Holds Internal Laser CP-13-0010-1A</i>
CP-13-0010-1A	Laser, Module, Internal	<i>Collimators with S/N less than A08323</i>
CP-13-0010-1C	Laser, Module, Externally Adjustable	<i>Not sold separate - Only as Assembly Collimator S/N > A08322</i>
CP-11-0124-1A	Assembly, Front, Adjustable Laser	<i>Includes the Laser Module</i>
CP-11-0125-1A	Assembly, Side, Adjustable Laser	<i>Includes the Laser Module</i>
	Lead	
CM-11-0090-1A	Assembly, Chassis Lead Aperture/Adhesive, CM	
CP-11-0091-1A	Assembly, Chassis Lead Aperture/Adhesive, CP	
CM-12-0115-1B	Lead, Front/Rear Chassis Shield, .016" Thick	
	Circuit Board	
CM-11-0673-1E	Assembly, LED Board/Backing Plate	<i>Check S/N for correct model CML 150/125/VET, MinXRay Units</i>
CP-11-SR673-1A	Assembly, LED Board/Backing Plate	<i>Check S/N for correct model SourceRay Units</i>
CM-11-0674-1A	Assembly, High Heat LED Board (Version B)	<i>CML 150/125/VET, MinXRay Models S/Ns greater than A14406</i>

CM-11-A674-1A	Upgrade Assembly, High Heat LED Board (Version B + Adapter Board)	Direct replacement for CM-11-0673 <i>'Plug and Play' replacement</i>
CP-13-0001-1A	Halogen Circuit Board	Check S/N for correct model <i>CM/CP Halogen Units</i>
CP-13-0077-1A	LED Power Conditioning Board	Check S/N for correct model <i>CML 150/125/VET Units</i>
CP-13-0066-1A	Connector. 6 Screw, 10 amp	<i>For LED Board</i>
CP-13-0080-1A	Connector. 8 Screw, 10 amp	<i>For LED Board</i>
CP-13-0079-1A	Fuse For LED Power Conditioning Board	
CM-11-0007-1A	Assembly, LED Cooling Fan	<i>Includes installation instructions</i>
	Halogen Units	
CP-13-0030-1B	100W 12V lamp	<i>MX Units</i>
CP-13-0031-1A	100W 24V lamp	<i>SR Units</i>
CP-13-0032-1A	150W 24V lamp	<i>CM Units</i>
CP-13-0020-1A	Thermal Switch	
CP-13-0040-1A	Lamp Base	

APPENDIX 1: ESSENTIAL PERFORMANCE AND RISK ANALYSIS

ESSENTIAL PERFORMANCE AND RISK ANALYSIS

SUMMARY

Testing performed for: Collimare, LLC

Product Used for Life Support: NO

For use in Shielded Enclosure: NO

The following information on Test Mode and Essential Performance was determined by manufacturing:

Mode of Operation	Essential Performance / Degradation of Performance
<p>For all emissions testing, the Collimare Models were operated at the maximum level of performance utilized by the end user per instructions provided herein.</p> <p>For all immunity testing of the Collimare Models, the system was operated in a test mode that is typical for the end user. All user functions including: lamp on and laser on were exercised and the full cycle was repeated for the duration of the test. The front panel switch was pressed to re-activate the lamp and laser on function for all the Collimare Models</p>	<p>Unallowable Actions during system operation: The lamp and lasers stay off.</p> <p>Essential Performance: The lamp and lasers must stay on or come back on.</p> <p>Degradation of Performance Not Allowed: Requirement of a power reset to restore function. Not to turn on during or after the event.</p> <p>Allowable Degradation of Performance: Lamp and lasers may go out during the event but must come back on after the event either automatically or by pressing the front panel switch.</p>

APPENDIX 2: ELECTROMAGNETIC EMISSIONS

GUIDANCE AND MANUFACTURER'S DECLARATION - ELECTROMAGNETIC EMISSIONS

Table A2.1: Electromagnetic Emissions 1

Guidance and manufacturer's declaration – electromagnetic emissions		
The Collimare Models are intended for use in the electromagnetic environment specified below. The customer or the user of the Collimare Models should assure that it is used in such an environment.		
Emissions test	Compliance	Electromagnetic environment – guidance
RF emissions CISPR 11	Group 1	The Collimare models use RF energy only for its internal function. Therefore, its RF emissions are very low and are not likely to cause any interference in nearby electronic equipment.
RF emissions CISPR 11	Class A	The Collimare Models are suitable for use in all establishments other than domestic and those directly connected to the public low-voltage power supply network that supplies buildings used for domestic purposes.
Harmonic emissions IEC 61000-3-2	Not applicable	
Voltage fluctuations/ flicker emissions IEC 61000-3-3	Not applicable	

Table A2.2: Electromagnetic Emissions 2

Guidance and manufacturer's declaration – electromagnetic emissions			
The Collimare Models are intended for use in the electromagnetic environment specified below. The customer or the user of the Collimare Models should assure that it is used in such an environment.			
IMMUNITY test	IEC 60601 test level	Compliance level	Electromagnetic environment – guidance
Electrostatic discharge (ESD) IEC 61000-4-2	±6 kV contact ±8 kV air	±6 kV contact ±8 kV air	Floors should be wood, concrete or ceramic tile. If floors are covered with synthetic material, the relative humidity should be at least 30 %.
Electrical fast transient/burst IEC 61000-4-4	±2 kV for power supply lines ±1 kV for input/output lines	Not applicable	Not applicable
Surge IEC 61000-4-5	±1 kV line(s) to line(s) ±2 kV line(s) to earth	Not applicable	Not applicable
Voltage dips, short interruptions and voltage variations on power supply input lines IEC 61000-4-11	<5 % U_T (>95 % dip in U_T) for 0,5 cycle 40 % U_T (60 % dip in U_T) for 5 cycles 70 % U_T (30 % dip in U_T) for 25 cycles <5 % U_T (>95 % dip in U_T) for 5 s	Not applicable	Not applicable
Power frequency (50/60 Hz) magnetic field IEC 61000-4-8	3 A/m	3 A/m	If degradation occurs, it may be necessary to position the Collimare Models further from sources of power frequency magnetic fields or to install magnetic shielding. The power frequency magnetic field should be measured in the intended installation location to assure that it is sufficiently low.
NOTE U_T is the a.c. mains voltage prior to application of the test level.			

Table A2.3: Electromagnetic Emissions 3

Guidance and manufacturer's declaration – electromagnetic emissions			
The Collimare Models are intended for use in the electromagnetic environment specified below. The customer or the user of the Collimare Models should assure that it is used in such an environment.			
IMMUNITY test	IEC 60601 TEST LEVEL	Compliance level	Electromagnetic environment – guidance
Conducted RF IEC 61000-4-6	3 Vrms 150 kHz to 80 MHz outside ISM bands	Not applicable	<p>Portable and mobile RF communications equipment should be used no closer to any part of the Collimare Models including cables, than the recommended separation distance calculated from the equation applicable to the frequency of the transmitter.</p> <p>Recommended separation distance</p> $d = 1,2\sqrt{P}$ $d = 1,2\sqrt{P}$ 80 MHz to 800 MHz $d = 1,2\sqrt{P}$ 800 MHz to 2,5 GHz
Radiated RF IEC 61000-4-3	3 V/m 80 MHz to 2,5 GHz	3 V/m	<p>where P is the maximum output power rating of the transmitter in watts (W) according to the transmitter manufacturer and d is the recommended separation distance in meters (m).^b</p> <p>Field strengths from fixed RF transmitters, as determined by an electromagnetic site survey,^c should be less than the compliance level in each frequency range.^d</p> <p>Interference may occur in the vicinity of equipment marked with the following symbol:</p> 
NOTE 1 At 80 MHz and 800 MHz, the higher frequency range applies.			
NOTE 2 These guidelines may not apply in all situations. Electromagnetic propagation is affected by absorption and reflection from structures, objects and people.			
<p>^a Field strengths from fixed transmitters, such as base stations for radio (cellular/cordless) telephones and land mobile radios, amateur radio, AM and FM radio broadcast and TV broadcast cannot be predicted theoretically with accuracy. To assess the electromagnetic environment due to fixed RF transmitters, an electromagnetic site survey should be considered. If the measured field strength in the location in which the Collimare Models referenced in the above chart is used exceeds the applicable RF compliance level above, the Collimare Models referenced in the above chart should be observed to verify normal operation. If abnormal performance is observed, additional measures may be necessary, such as re-orienting or relocating the Collimare Models referenced in the above chart over the frequency range 150 kHz to 80 MHz, field strengths should be less than 3 V/m.</p>			

Table A2.4: Electromagnetic Emissions 4

Recommended separation distances between portable and mobile RF communications equipment and the Collimare Models			
The Collimare Models are intended for use in an electromagnetic environment in which radiated RF disturbances are controlled. The customer or the user of the Collimare Models can help prevent electromagnetic interference by maintaining a minimum distance between portable and mobile RF communications equipment (transmitters) and the Collimare Models, as recommended below, according to the maximum output power of the communications equipment.			
Rated maximum output power of transmitter W	Separation distance according to frequency of transmitter m		
	150 kHz to 80 MHz $d = 1,2\sqrt{P}$	80 MHz to 800 MHz $d = 1,2\sqrt{P}$	800 MHz to 2,5 GHz $d = 2,3\sqrt{P}$
0,01	0,12	0,12	0,23
0,1	0,38	0,38	0,73
1	1,2	1,2	2,3
10	3,8	3,8	7,3
100	12	12	23

For transmitters rated at a maximum output power not listed above, the recommended separation distance d in metres (m) can be determined using the equation applicable to the frequency of the transmitter, where P is the maximum output power rating of the transmitter in watts (W) according to the transmitter manufacturer.

NOTE 1 At 80 MHz and 800 MHz, the separation distance for the higher frequency range applies.

NOTE 2 These guidelines may not apply in all situations. Electromagnetic propagation is affected by absorption and reflection from structures, objects and people.

APPENDIX 3: COMPLIANCE VERIFICATION

COMPLIANCE VERIFICATION

It is necessary for the assembler to verify compliance. A series of tests, when performed at the time of installation, will indicate compliance with 21 CFR, Sub-Chapter J, Part 1020, Performance Standards.

The following tests are from the NEMA Standards Publication, No. XR 8-1979 (Test Methods for Diagnostic X-ray Machines for Use During Initial Installation).

For each compliance item, there may be a variety of test methods described. Which method is used will depend on the tester's experience, availability of equipment, time, or special requirements of the X-Ray Room or Collimator. Any reference tolerances on compliance items are referenced directly from 21 CFR, Sub-Chapter J, Regulations. They do not take into account inaccuracies brought about by the test equipment, instrumentation, or the human element. These factors must be considered when these tests are performed, and the compliance of the equipment is being determined.

A3.1 - LIST OF FIGURES AND TABLES

- **Figure A3.1** General Set-Up BRH/FDA Test Stand
- **Figure A3.2** BRH/FDA Test Stand Showing Chamber Mounting Slots
- **Figure A3.3** Light Field vs. X-Ray Field Error Measurements
- **Figure A3.4** Determination of SID
- **Figure A3.5** Metal Marker Method
- **Table A3.1** Minimum Beam Quality Requirements
- **Table A3.2** Aluminum Equivalent Of Primary Beam Total Filtration

A3.2 - VERIFICATION TESTS TO BE PERFORMED

<u>Test Procedure or Requirement</u>	<u>Applicable Paragraph</u>
● Determination of Half Value Layer (Beam Quality)	XR8/2.09 - Page 57
● Actual Versus Indicated Source-To-Image Distance (SID)	XR8/2.13 - Page 59
● Visual Definition of X-ray Light-Field	XR8/2.14 - Page 60
● Intensity of Light Field Illumination	XR8/2.15 - Page 63
● X-ray Field/Receptor Center Alignment	XR8/2.17 - Page 64
● Indication of Field Size	XR8/2.18 - Page 65
● X-ray Field Limitation and Alignment	XR8/2.20 - Page 66
● Compliance Verification Record Sheet	APPENDIX 4

RECORD THE RESULTS ON THE RECORD SHEET SUPPLIED IN APPENDIX 4 - Page 68.

GENERAL SET-UP BRH/FDA TEST STAND

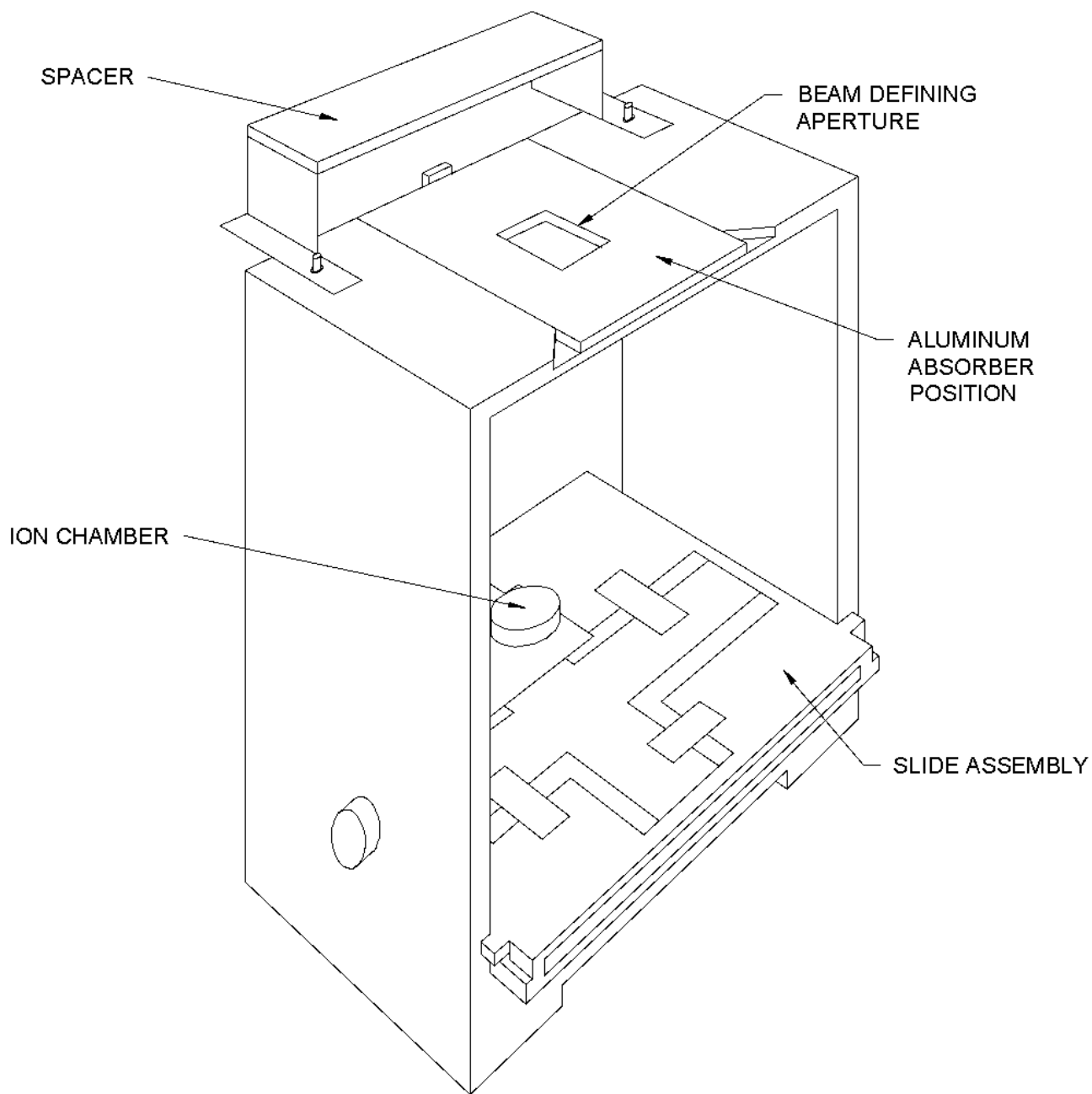
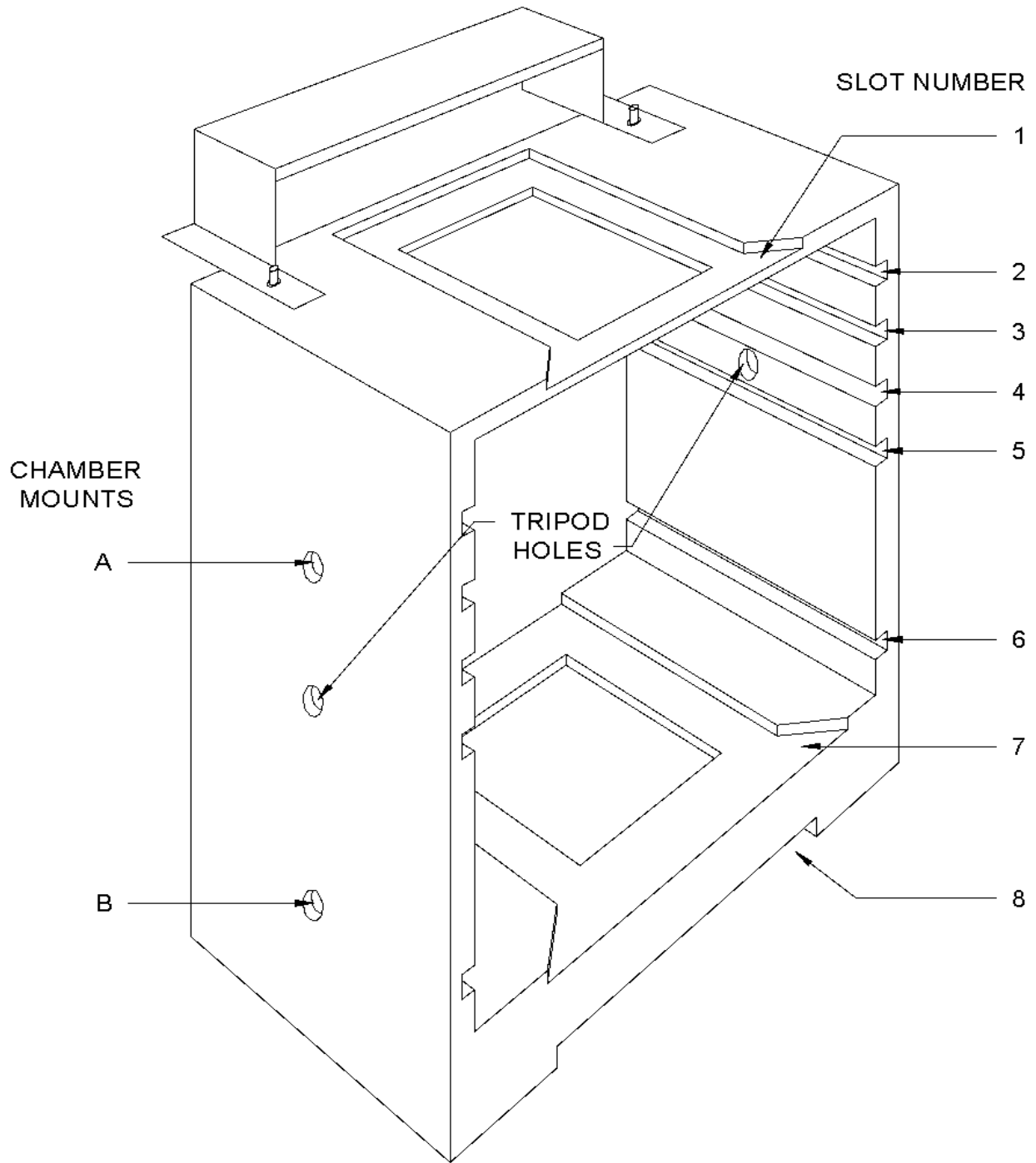

Figure A3.1 - General Set-up BRH/FDA Test Stand

BRH/FDA TEST STAND SHOWING CHAMBER MOUNTING SLOTS



LEFT SIDE MOUNTING HOLES FOR COMPLIANCE TESTING

Figure A3.2 - BRH/FDA Test Stand Showing Chamber Mounting Slots

LIGHT FIELD VS. X-RAY FIELD ERROR MEASUREMENTS

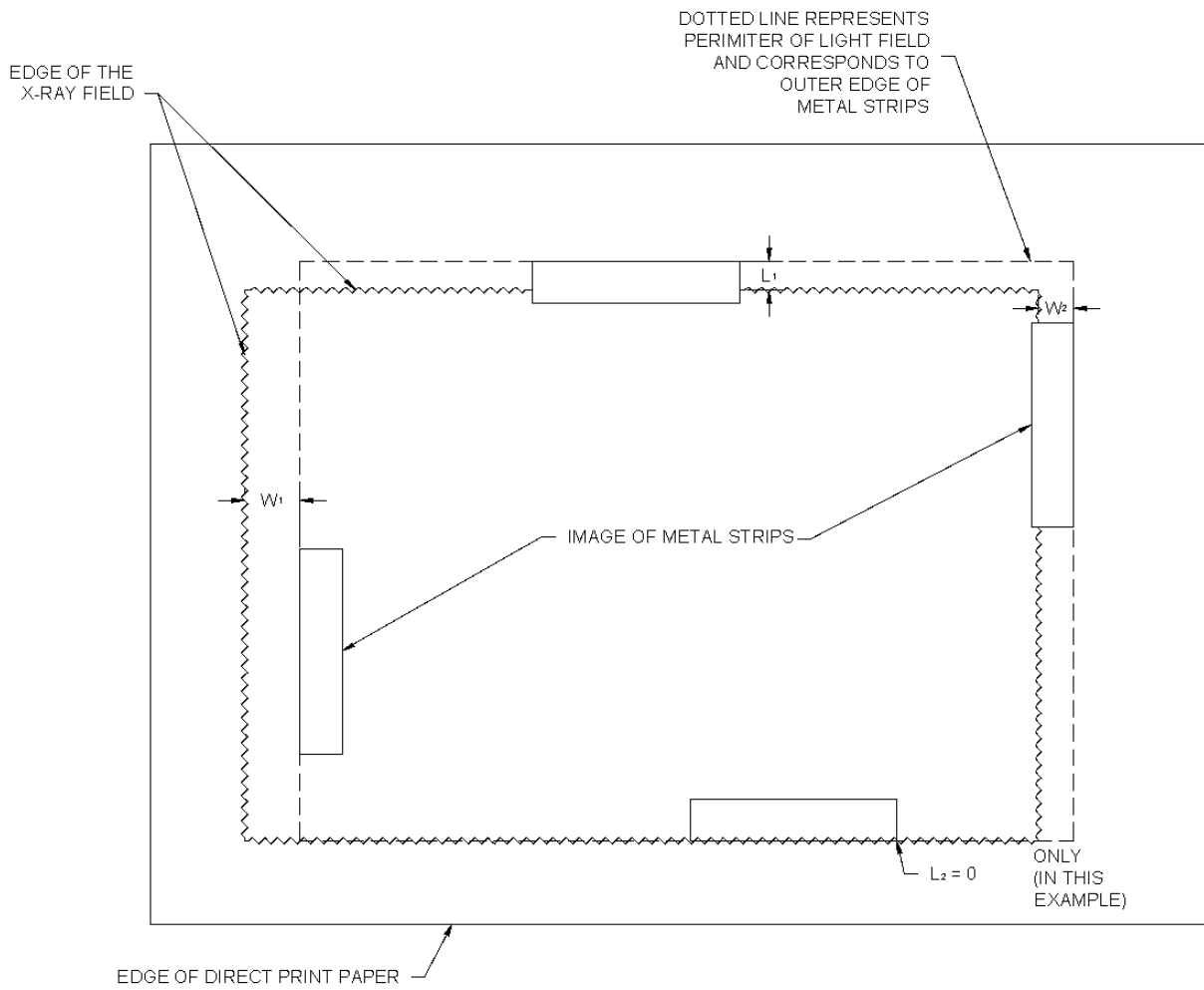
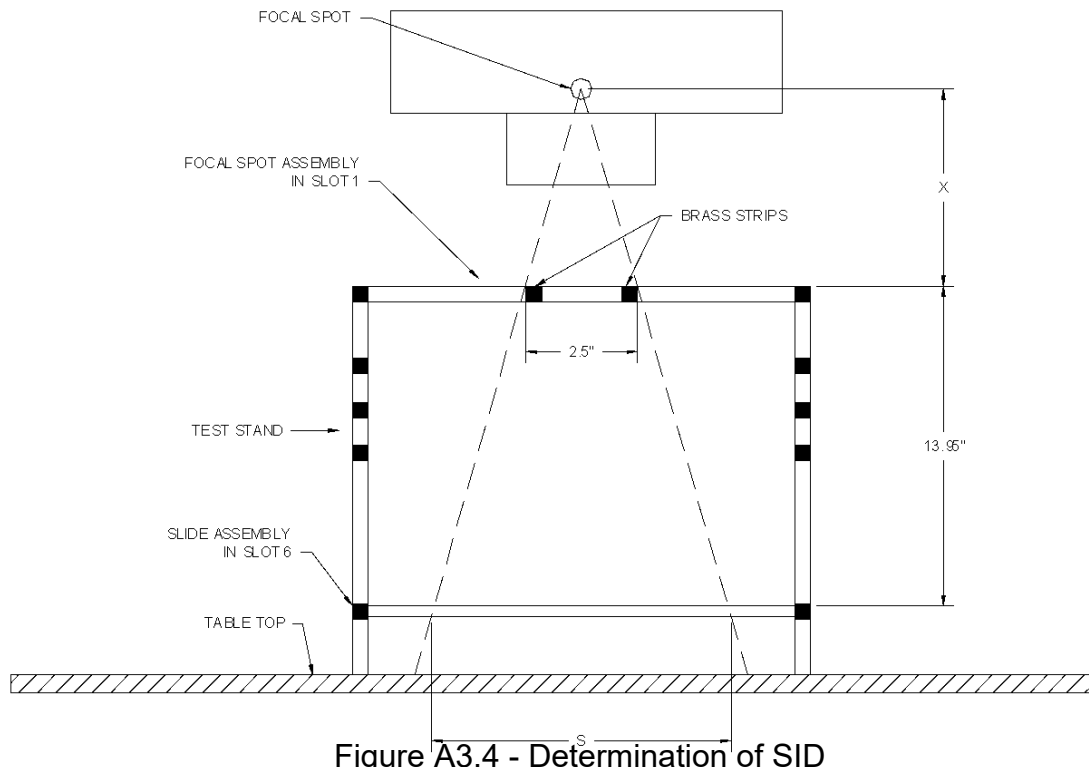

Figure A3.3 - Light Field vs. X-Ray Field Error Measurements

DETERMINATION OF SID



METAL MARKER METHOD

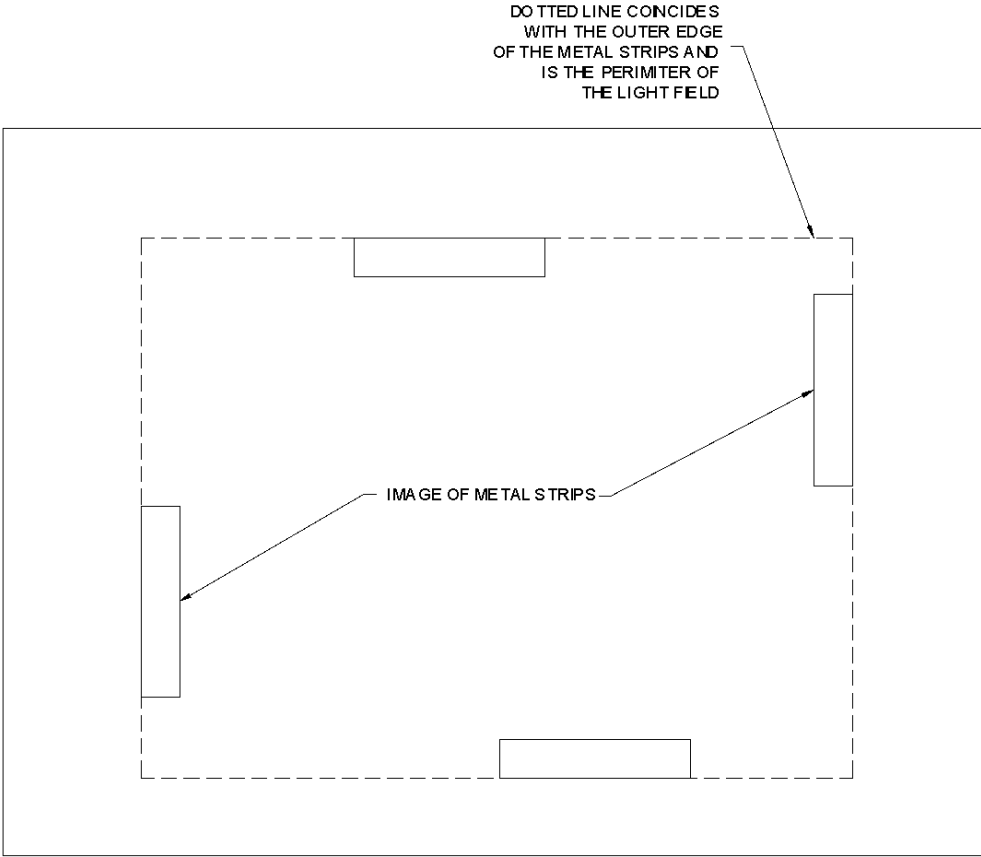

Figure A3.5 - Metal Marker Method

A3.3 - XR8/2.09 BEAM QUALITY (HALF-VALUE LAYER (HVL))

REQUIREMENT - The minimum beam quality requirements listed in Table 1 shall be met.

A3.3.1 - METHOD I - VISUAL DETERMINATION OF HALF-VALUE LAYER (HVL)

General:

The above HVL requirement will be considered to have been met if it can be demonstrated that the aluminum equivalent of the total filtration in the primary beam is not less than that shown in Table 2.

Equipment:

None required.

Table A3.1 - Minimum Beam Quality Requirements

KVp Range	Measured kVp	HVL (mm of Al)		
		1*	2*	3*
Below 51.....	30	1.5	0.3	0.3
	40	1.5	0.4	0.4
	49	1.5	0.5	0.5
51 to 70.....	50	1.5	1.2	1.3
	60	1.5	1.3	1.5
	70	1.5	1.5	1.8
Above 70.....	71	2.1	2.1	2.5
	80	2.3	2.3	2.9
	90	2.5	2.5	3.2
	100	2.7	2.7	3.6
	110	3.0	3.0	3.9
	120	3.2	3.2	4.3
	130	3.5	3.5	4.7
	140	3.8	3.8	5.0
150	4.1	3.8	5.4	

1* - Specified Dental Systems: Dental x-ray systems designed for use with intraoral image receptors and manufactured after Dec. 1, 1980

2* - Other X-Ray Systems: Dental x-ray systems designed for use with intraoral image receptors and manufactured before or on Dec 1, 1980, and all other x-ray systems subject to this section and manufactured before June 10, 2006

3* - Other X-Ray Systems: All x-ray systems, except dental x-ray systems designed for use with intraoral image receptors, subject to this section and manufactured on or after June 10, 2006.

Table A3.2 - Aluminum Equivalent Of Primary Beam Total Filtration

OPERATING VOLTAGE (kVp)	TOTAL FILTRATION (mm Al Equivalent)
Below 50.....	0.5
50 - 70.....	1.8
Above 70.....	2.5

Procedure:

Visually inspect the system and determine the aluminum equivalence of the total filtration in the primary beam. This includes the inherent filtration of the X-ray tube, X-ray tube housing, beam-limiting device, and any additional filtration that may have been added in the useful beam (in fluoroscopic systems the tabletop is included as part of the added filtration).

Verification Of Compliance:

The aluminum equivalence of the total filtration must be equal to or greater than the amount specified in Table 2.

A3.3.2 - METHOD 2 - STANDARD ABSORBER METHOD

General:

This test is to be used when the surveyor cannot remove or see the total filtration equivalence.

The HVL determinations obtained from the following procedures are to be compared with those illustrated in Table 1. The HVL in millimeters of aluminum of the system being tested must be greater than or equal to the values shown in Table 1.

Equipment:

- Radiation detector.
- Standard absorber with equivalent filtration of 2.5 millimeters of aluminum.

Procedure:

With the detection device positioned horizontally, an exposure is made at a preselected technique factor of 80 kVp and appropriate mA and time. The reading of the radiation output is recorded.

Position a total of 2.5 millimeters of aluminum at the port of the beam-limiting device and repeat the exposure using the same technique factors. Record the radiation output.

For X-ray units operating at low kVp (less than 50) and for mammography units, it will be necessary to use an aluminum absorber of 0.6 millimeters at 49 kVp.

Verification Of Compliance:

Verify that the radiation output in Step 2 is greater than or equal to 50 % of the radiation output in Step 1.

A3.4 - XR8/2.13 ACTUAL VERSUS INDICATED SOURCE-TO-IMAGE DISTANCE (SID)

REQUIREMENT-Means shall be provided to indicate when the axis of the X-ray beam is perpendicular to the plane of the image receptor, to align the center of the X-ray field with respect to the center of the image receptor to within 2 percent of the source to image distance (SID), and to indicate the SID to within 2 percent.

A3.4.1 - METHOD 1 - DIRECT MEASUREMENT METHOD

General:

In order to perform this test it is necessary that the focal spot location be known.

Equipment:

- Graduated scale.

Procedure:

1. Set the tube unit to an appropriate SID and record this value.
2. Using the graduated scale measure the distance from the plane of the image receptor to the surface of the table top and record this distance as distance A.
3. Using the graduated scale measure the distance from the tabletop to the bottom of the beam limiting device and record this distance as distance B.
4. Add distances A and B to the known focal spot location; this quantity is the actual SID.
5. Multiply the actual SID determined in Step 4 by 2 percent and record.

Verification and Compliance:

The indicated value of the SID recorded in step 1 must fall within the value of the actual SID determined in step 4 plus or minus the value determined in step 5.

A3.4.2 - METHOD 2 - TRIANGULATION METHOD

General:

The image of the radiation field on the film must be of uniform density with sharply defined edges. The graduated template is utilized to minimize the amount of error introduced into the measurement and calculation of the SID.

Equipment:

- Manufacturer's recommended test stand.
- Cassettes with film or direct print paper.
- Graduated template.

Procedure:

1. Align the tube unit with the image receptor and select an appropriate SID with the normal operating aids (detents, scales, lights, etc.) provided.
2. Load the cassette and insert into the image receptor.
3. Position the test stand according to the manufacturer's instructions.
4. Load a second cassette and place in the designated position on the test stand. Make certain that the graduated template is in a position above the second cassette (Figure 14).
5. Select the proper technique factors, make an exposure, and develop the film or direct print paper.
6. Calculate the magnification factor by measuring the distance between the same two points on the graduated template image on each of the two films. The two points chosen must be as far apart as possible. Divide the larger measurement by the smaller measurement to determine the magnification factor.
7. If the source to test stand film distance is known, calculate the actual SID by multiplying the magnification factor by the source to test stand film distance.
8. If the source to test stand film distance is not known, measure the actual distance from the graduated template position to the test stand film plane (distance Z).
9. Calculate the source to template distance (distance X) using the following formula:
10. Calculate the source to test stand film distance by adding the distance X and the distance Z. Multiply the source to the test stand.

A3.5 - XR8/2.14 VISUAL DEFINITION (RADIOGRAPHIC) OR X-RAY LIGHT-FIELD

REQUIREMENT - Means shall be provided for visually defining the perimeter of the X-ray field. The total misalignment of the edges of the visually defined field with the respective edges of the X-ray field along either the length or width of the visually defined field shall not exceed 2 percent of the distance from the source to the center of the visually defined field when the surface upon which it appears is perpendicular to the axis of the X-ray beam.

A3.5.1 - METHOD I - BRH/FDA COMPLIANCE TEST METHOD

Equipment:

- BRH/FDA compliance test stand (including slide assembly).
- Four metal marker strips.
- Plastic cassette, loaded with direct-print paper or film.

Procedure:

1. Attach the spacer, positioned out of the primary beam to the test stand. Center the stand on the table. Center the source over the stand, assure by the means provided that the axis of the X-ray beam is perpendicular to the plane of the image receptor, and bring the beam-limiting device down into firm contact with the spacer. Select the MANUAL mode of operation (there must not be a cassette in the cassette holder).
2. Insert the slide assembly, grid side up, into slot 6 of the test stand and the focal spot assembly into slot 1. Place a cassette loaded with direct-print paper or film into the slide assembly.
3. Adjust the collimator such that no part of the light-field intersects any portion of the top of the test stand. (Further collimation to a light-field of less than 15 by 20 centimeters (6 by 8 in) on the slide assembly grid may be desirable to assure that the X-ray field will be fully contained on the direct-print paper or film in the slide assembly).
4. Position the outer edge of each metal strip to correspond with each side of the light-field. One end of the metal strip shall extend to the center line of the respective grid arm.
5. Select proper technique factors and make an exposure (may require several exposures to obtain 1 R to the direct-print paper).
6. Develop the direct-print paper or film.

Verification Of Compliance:

For determination of misalignment, compare the edges of the X-ray field to the edges of the light-field as defined by the outer edges of the metal strips. On each side of the rectangular fields, measure the separation between the X-ray field and the outside edge on the image of the respective metal strip. Sum these measured separations for opposite sides of the X-ray field to yield a total misalignment in the length and width dimensions. Record the length misalignment and width misalignment, both without regard to sign.

Calculations:

Calculate the source-to-image distance (SID) per the following formula as the indicated source-to-table-top distance minus 4.7 centimeters (1.85in) and record. Calculate 2 percent of this SID and record. Both the length and the width misalignment must be less than 2 percent of SID.

$$\frac{2.5}{S} \frac{X}{X + 13.95}$$

$$2.5X + (2.5) 13.95 = XS$$

$$13.95 = XS - 2.5X$$

$$34.875 = X(S - 2.5)$$

$$X = \frac{34.875}{S - 2.5}$$

The misalignments are calculated:

$$\begin{aligned} \text{Length misalignment} &= L1 + L2 \leq 2\% \text{ SID} \\ \text{Width misalignment} &= W1 + W2 \leq 2\% \text{ SID} \end{aligned}$$

Calculate 2 % of the measured SID. Each of the misalignments, length or width, must be less than or equal to 2 % of the measured SID for compliance.

A3.5.2 - METHOD 2 - METAL MARKER METHOD

General:

The actual versus indicated source-to image distance (SID) test must be performed prior to attempting this test.

Equipment:

- Plastic cassette with direct-printer paper or film.
- Radio-opaque markers.*
*Each marker is approximately 1/32 inch galvanized sheet metal having the dimensions of 1.5 by 1.5 inches.

Procedure:

1. Adjust the source assembly and the beam-limiting device so that they are approximately centered over the table and perpendicular to the table top. Then position the beam-limiting device to the SID previously determined and record the indicated value.
2. Insert the cassette and turn on the light-field.
 - a. Adjust the beam-limiting device to the next size smaller than the cassette size being used.
 - b. Make a note to record the field size indicated on the dial of the beam-limiting device for the SID being used.
3. Position the outer edge of each metal marker on the tabletop to correspond with each side of the light-field.
4. Select the appropriate technique factors and make an exposure.
5. Develop film or direct-print paper.

Verification Of Compliance:

For determination of misalignment, compare the edges of the X-ray field to the edges of the light-field as defined by the outer edges of the metal strips. On each side of the rectangular fields, measure the separation between the X-ray field and the outside edge of the image of the respective metal strip. Sum these measured separations for opposite sides of the X-ray field to yield a total misalignment in the length and width dimensions. Record the length misalignment and width misalignment, both without regard to sign.

Calculations:

$$\frac{2.5}{S} \frac{X}{X + 13.95}$$

$$2.5X + (2.5) 13.95 = XS$$

$$13.95 = XS - 2.5X$$

$$34.875 = X(S - 2.5)$$

$$X = \frac{34.875}{S - 2.5}$$

S - 2.5

The misalignments are calculated:

$$\begin{aligned}\text{Length misalignment} &= L1 + L2 \leq 2\% \text{ SID} \\ \text{Width misalignment} &= W1 + W2 \leq 2\% \text{ SID}\end{aligned}$$

Calculate 2 % of the measured SID. Each of the misalignments, length or width, must be less than or equal to 2 % of the measured SID for compliance.

A3.5.3 - METHOD 3 - ALTERNATE TEST STAND METHOD

General:

The image of the radiation field on the film must be of uniform density with sharply defined edges. The graduated template is utilized to minimize the amount of error introduced into the measurement of the X-ray field size.

The actual versus indicated SID must be determined prior to performing this test.

Equipment:

- Manufacturer's recommended test stand.
- Cassettes and film.
- Graduated template.

Procedure:

1. Align the tube unit and image receptor and set the SID with the normal operating aids (detents, scales, lights, etc.)
2. Load cassette and insert into image receptor.
3. Close shutters to a size smaller than that of the cassette placed into the image receptor.
4. Position the test stand in accordance with the manufacturer's instructions.
5. Energize the field light and record or define the position of the four light field edges as shown on the graduated template or position four metal markers so that the outer edge of each metal marker corresponds to an edge on each side of the light-field or both.
6. Select proper technique factors, make an exposure, and develop film.

Verification Of Compliance:

1. Calculate 2 percent of the actual SID and record.
2. Compare the edges of the X-ray field to the edges of the light-field as defined by the outer edges of the metal markers or by the graduated scale.
3. Measure the distance between the edges of the two fields for each side of the rectangular fields.
4. Arithmetically sum the misalignment of opposite sides, regardless of sign, of the rectangles, to yield misalignment in each of the two directions.

$$\begin{aligned}\text{Length misalignment} &= L1 + L2 \leq 2\% \text{ SID} \\ \text{Width misalignment} &= W1 + W2 \leq 2\% \text{ SID}\end{aligned}$$

Both the length and the width misalignment must be less than 2 % SID as calculated in Step 1.

A3.6 - XR8/2.15 INTENSITY OF LIGHT-FIELD ILLUMINATION

REQUIREMENT - When a light localizer is used to define the X-ray field, it shall provide an average illumination of not less than 160 lux (15 footcandles) at 100 centimeters or at the maximum source-to-image distance (SID), whichever is less. The average illumination shall be based on measurements in the approximate center of each quadrant of light-field.

A3.6.1 - METHOD 1 - DIRECT TEST

General:

Make certain that all surfaces in the light path are clean.
Reduce ambient light level as much as is feasible.

Equipment:

- Photometer capable of measuring 160 lux (15 footcandles).

Procedure:

1. Place the photometer in the tabletop and set the diagnostic source assembly such that the sensing area of the photometer is at 100 centimeters or the maximum SID, whichever is less.
2. Open the beam-limiting device to assure that each quadrant of the light-field is larger than the sensing area of the photometer.
3. Refer to the manufacturer's instructions for proper use of the photometer.
4. Turn on the light localizer.
5. At or near the center of a light-field quadrant, determine the illuminance by subtracting the ambient light level from the corresponding light level as measured when the light localizer is energized. Do not move the photometer between measurements.
6. Repeat the procedure for the remaining three quadrants.
7. Determine the average illuminance of the four light field quadrants.
8. Record the model number, serial number, and the date of calibration of the test instrument.

Verification Of Compliance:

Verify that the average illumination is not less than 160 lux (15 footcandles).

A3.6.2 - METHOD 2- INDIRECT TEST

General:

This indirect test is feasible after the correlation between light output and voltage is made; the manufacturer then specifies a voltage to be measured or adjusted, or both.

Make certain that all surfaces in the light path are clean and unobstructed.

Equipment:

- Digital Voltmeter

Procedure:

1. Remove trim covers to gain access to the lamp socket.
2. Verify that the specified lamp is in the socket.
3. With the light-field energized, measure the voltage across the lamp socket terminals.
4. Record the voltage measured.
5. Record the model number, serial number and calibration date of the digital voltmeter.

Verification Of Compliance:

The voltage recorded shall be within the tolerances specified by the manufacturer.

A3.7 - XR8/2.17 X-RAY FIELD/RECEPTOR CENTER ALIGNMENT

REQUIREMENT - Means shall be provided to align the center of the X-ray field with respect to the image receptor to within 2 percent of the source-to-image distance (SID).

General:

All exposures taken during this test must have a uniform film density of approximately 1.0. Actual versus indicated SID must be determined prior to performing this test.

Equipment:

- Radiographic cassette loaded with film (8 by 10 inches).

Procedure:

1. Load cassette with film and place into the bucky tray.
2. Assure that the X-ray beam is perpendicular to the image receptor and centered over the bucky tray.
3. Set the SID to the value determined in the actual versus indicated SID test.
4. Reduce the X-ray field to approximately 6 by 8 inches.
5. Make an exposure and develop the film.
6. To determine as accurately as possible the corners of the image recorded on the film, locate two points on each of the four sides of the image. Through the two points on each side draw a straight line. These four lines, when extended, intersect making a rectangle which is a close approximation of the actual X-ray field. Draw a diagonal across the image to determine the center of the X-ray image.
7. To determine the center of the X-ray film, draw diagonals across the film (the point where these two lines cross is the center of the film), or fold the film into quarters (the point where the two folds cross is the center of the film).
8. The distance from the film center mark to the image center mark is measured and recorded as the linear displacement or misalignment or the centers of the X-ray field and the image receptor.

Verification Of Compliance:

Verify that this distance is less than or equal to 2 percent of the SID.

A3.8 - XR8/2.18 INDICATION OF X-RAY FIELD SIZE

REQUIREMENT - Means shall be provided on the beam-limiting device to indicate field size in the image receptor plane to within 2 percent of the source-to-image distance (SID). (See 21CFR 1020.31(e)(1).)

General:

The actual versus indicated SID test must be performed prior to beginning this test.

Equipment:

- A 24-by 30-centimeter or a 10 by 12 inch cassette with film.

Procedure:

1. Set the SID to the value determined in the actual versus indicated SID test.
2. Center the film cassette in the cassette tray and insert into position.
3. Adjust the field size to 15 by 15 centimeters or 8 by 8 inches by means of the numerical indicators on the beam-limiting device.
4. Make an exposure and develop film.
5. Measure and record the length and width dimensions of the image.

Verification Of Compliance:

The deviation of any of the recorded dimensions must not exceed 2 percent of the SID in Step 1.

A3.9 - XR8/2.20 X-RAY FIELD LIMITATION AND ALIGNMENT

REQUIREMENT - The X-ray field size in the plane of the image receptor, whether automatically or manually adjusted, shall be such that neither the length nor the width of the X-ray field differs from that of the image receptor by greater than 3 percent of the source-to-image distance (SID) and that the sum of the length and width differences without regard to sign be no greater than 4 percent of the SID, when the equipment indicates that the beam axis is perpendicular to the plane of the image receptor.

A3.9.1 - METHOD 1 - FDA/CDRH TEST STAND METHOD

Equipment:

- BRH/FDA compliance test stand with accessories.
- Slide assembly.
- Plastic cassette containing a sheet of direct-print paper or X-ray film.
- Ruler.
- Cassette (preferably 8 by 10 inches or smaller).

Procedure:

1. Using the means provided, align the source assembly such that the beam axis is perpendicular to the image receptor.
2. Place the stand on the table.
3. Position the spacer so as not to intersect the primary beam and secure with the push button connectors.
4. Center the source assembly over the test stand using the means provided, e.g., the light-field used to define the X-ray field.
5. Bring the source assembly down onto firm contact with the spacer.
6. Center the cassette tray with the source assembly using the means provided, e.g., bucky light.
7. Insert the plastic cassette into the slide assembly. Then insert the slide assembly into slot 5. (See Figure 12 BRH/FDA Test Stand Showing Chamber Mounting Slots)
8. Center the film cassette in the cassette tray and insert into position. If the positive-beam limitation will not operate at this SID, raise the source assembly and lock in position at the first operable SID.
9. Make an exposure. Develop the image. Measure and record the length and width dimensions of the image.
10. Calculate the field size correction factor as the SID/A where:

SID is the indicated source-to-image receptor distance, and:
A is the indicated source-to-tabletop distance less 7.7 inches. Multiply each of the measured dimensions by the correction factor.

X-ray field length at:

$$\text{under-table image receptor} = \frac{\text{SID}}{\text{A}} \times (\text{X-ray field length at slot 5})$$

X-ray field width at:

$$\text{under-table image receptor} = \frac{\text{SID}}{\text{A}} \times (\text{X-ray field width at slot 5})$$

Determine the difference without regard to sign between the corrected length and width dimensions and the corresponding cassette film size dimensions (8 by 10, 5 by 7, etc.). Each of these differences must be less than 3 percent of the SID, and the sum of these differences must be less than 4 percent of the SID.

A3.9.2 - METHOD 2 - ALTERNATE TEST STAND METHOD

General:

Prior to performing this test, the magnification factor must be determined in accordance with the X-ray/Light-Field Alignment Test - Method III.

Equipment:

- Manufacturer's recommended test stand.
- Cassette with film.

Procedure:

1. Align the tube unit and image receptor and set SID to the value determined in the actual versus indicated SID test.
2. Insert an empty 8 by 10 inch cassette into the bucky tray.
3. Position test stand in accordance with manufacturer's instructions.
4. Load a second cassette and place it in the designated position.
5. Select the proper technique factors, make an exposure, and develop film.
6. Measure the length and width of the X-ray image on the film.
7. Multiply each measurement by the magnification factor previously determined.

Verification Of Compliance:

Verify that the X-ray field size in the plane of the image receptor does not differ from that of the image receptor by greater than 3 percent of the SID and that the sum of the length and width differences without regard to sign is no greater than 4 percent of the SID.

A3.9.3 - METHOD 3 - CASSETTE METHOD

General:

This can be used only when capability is provided for overriding positive-beam limitation.

Equipment:

- Large cassette with film.
- Small cassette, empty.

Procedure:

1. Insert an empty smaller cassette into the bucky tray.
2. Switch system to the override mode.
3. Remove the smaller cassette and insert the loaded large cassette.
4. Select the proper technique factors, make an exposure, and develop film.
5. Measure the length and width of the X-ray image on the film.

Verification Of Compliance:

Verify that the X-ray field size in the plane of the image receptor does not differ from that of the image receptor (smaller cassette) by greater than 3 percent of the SID and that the sum of the length and width differences without regard to sign is not greater than 4 percent of the SID

APPENDIX 4: COMPLIANCE VERIFICATION RECORD SHEET

This sheet is to be used by the assembler to assure that all points of compliance verification are covered.

INSTALLATION SITE: _____

DATE OF INSTALLATION: _____

INSTALLATION TECHNICIAN: _____

Requirements	Applicable Paragraph	Installation Date:	Completed: Initial Here	Date:	Date:	Date:
Determination of Half-Value Layer	XR8/2.09 Page: 53					
Actual Vs. Indicated SID	XR8/2.13 Page: 55					
Visual Definition of X-Ray Light Field	XR8/2.14 Page: 56					
Intensity of Light-Field	XR8/2.15 Page: 59					
X-Ray Field/Receptor Center Alignment	XR8/2.17 Page: 60					
Indication of Field Size	XR8/2.18 Page: 61					
X-Ray Field Limitation & Alignment	XR8/2.20 Page: 62					
Cassette Tray/Inspection Cleaning						
Electrical Cable Inspection						

RECORD SHEET NOTES:
